

USER'S MANUAL
Of
Intel945GC Express Chipset
&
Intel FW82801G ICH Chipset
Based
M/B For Intel ATOM Processor Ready

No. *G03-ATOMGM1-F*

Rev: 1.0

Release date: Feb, 2009

Trademark:

* Specifications and Information contained in this documentation are furnished for information use only, and are subject to change at any time without notice, and should not be construed as a commitment by manufacturer.

TABLE OF CONTENT

CHAPTER 1 INTRODUCTION OF INTEL ATOM230/330 MOTHERBOARD SERIES	
1-1 FEATURES OF MOTHERBOARD	1
1-1.1 SPECIAL FEATURES OF MOTHERBOARD.....	2
1-2 SPECIFICATION.....	3
1-3 ITEM CHECKLIST	4
1-4 LAYOUT DIAGRAM & JUMPER SETTING	4
CHAPTER 2 HARDWARE INSTALLATION	
2-1 INSTALL MEMORY	5
2-2 EXPANSION CARDS	6
CHAPTER 3 CONNCTORS, HEADERS & JUMPERS SETTING	
3-1 CONNECTORS	7
3-2 HEADERS	10
CHAPTER 4 USEFUL HELP	
4-1 HOW TO UPDATE BIOS.....	13
4-2 TROUBLE SHOOTING	14

Environmental Protection Announcement

Do not dispose this electronic device into the trash while discarding. To minimize pollution and ensure environment protection of mother earth, please recycle.





Safety Environmental Instruction

- Avoid the dusty, humidity and temperature extremes. Do not place the product in any area where it may become wet.
- 0 to 40 centigrade is the suitable temperature. (The figure comes from the request of the main chipset)
- Generally speaking, dramatic changes in temperature may lead to contact malfunction and crackles due to constant thermal expansion and contraction from the welding spots' that connect components and PCB. Computer should go through an adaptive phase before it boots when it is moved from a cold environment to a warmer one to avoid condensation phenomenon. These water drops attached on PCB or the surface of the components can bring about phenomena as minor as computer instability resulted from corrosion and oxidation from components and PCB or as major as short circuit that can burn the components. Suggest starting the computer until the temperature goes up.
- The increasing temperature of the capacitor may decrease the life of computer. Using the close case may decrease the life of other device because the higher temperature in the inner of the case.
- Attention to the heat sink when you over-clocking. The higher temperature may decrease the life of the device and burned the capacitor.

Chapter 1

Introduction of Intel® 945GC Motherboard Series

1-1 Features of motherboard

The Intel® 945GC chipset motherboard series are based on the latest Intel 945GC Express Chipset and Intel® FW82801G ICH Chipset technology. The motherboard is optimized to deliver innovative features and professional desktop platform solution with the advantages of the new generation dual core processor for those who demand the best experience of personal computing.

The Intel® 945GC chipset motherboard series for Intel® ATOM 230/330 Processor are absolutely the cost-effective solution for game enthusiasts and applications, and it also meets the demanding usage of computing of gaming, multimedia entertainment and business applications. Moreover, the Intel® 945GC express chipset incorporates Intel® Graphics Media Accelerator 950 which support the Microsoft* DirectX* 9, Vertex Shader 3.0 and Transform and Lighting provides incredible visual quality, faster graphics performance and flexible display options without the need for a separate graphics card.

The motherboard implements Intel® 945GC Express Chipset which supports Front Side Bus 533 MHz of data transferring and offers with 266 MHz memory clock frequency for Dual channel DDR2 533 MHz memory DIMMs which are expandable to 4GB to double the performance of memory access. The motherboard is embedded with ICH7 chipset of providing one parallel Ultra ATA 100 interface for two IDE drives and two serial ATA2 interface of 3.0Gb / s data transfer rate for two serial ATA devices.

The motherboards offer two 32-bit PCI slots guarantee the rich connectivity for the I/O of peripherals. And one PCI Express x1 I/O slots.

The motherboards provide 10 / 100 Ethernet compatible LAN function by using the Realtek RTL8102EL Megabit LAN which supports 10M / 100M data transfer rate. The motherboard series also have an integrated HD 6-channel ALC662 on board.

Embedded USB controller as well as capability of expanding to 8 of USB2.0 functional ports delivering 480Mb/s of rich connectivity, these motherboards meet the demands of future USB peripherals which are also equipped with hardware monitor function on system to monitor and protect your system and maintain your non-stop business computing.

Special feature---CPU Thermal Throttling /CPU Smart Fan In this motherboard are designed for power user to use the over-clocking function in more flexible ways. But please be caution that the over-clocking maybe causes the fails in system reliabilities. This motherboard provides the guaranteed performance and meets the demands of the next generation computing. But if you insist to gain more system performance with variety possibilities of the components you choose, please be careful and make sure to read the detailed descriptions of these value added product features, please get them in the coming section.

1-1.1 Special Features of Motherboard

CPU Thermal Throttling Technology--- (The CPU Overheat Protection Technology)
To prevent the increasing heat from damage of CPU or accidental shutdown while at high workload, the CPU Thermal Throttling Technology will force CPU to enter partially idle mode from 87.5% to 12.5% according to preset CPU operating temperature in BIOS (from 40 °C to 90°C). When the system senses the CPU operating temperature reaching the preset value, the CPU operating bandwidth will be decreased to the preset idle percentage to cool down the processor. When at throttling mode the beeper sound can be optionally selected to indicate it is in working.

CPU Smart Fan---(The Noise Management System)

It's never been a good idea to gain the performance of your system by sacrificing its acoustics. CPU Smart Fan Noise Management System is the answer to control the noise level needed for now-a-day's high performance computing system. The system will automatically increase the fan speed when CPU operating loading is high, after the CPU is in normal operating condition, the system will low down the fan speed for the silent operating environment. The system can provide the much longer life cycle for both CPU and the system fans for game use and business requirements.

1-2 Specification

Spec	Description
Design	* Micro ATX form factor 4 layers PCB size: 22.8*18cm
Chipset	* Intel [®] 945GC Memory Controller Hub (MCH) Chipset * Intel [®] 82801G I/O Controller Hub (ICH7) Chipset
CPU ATOM 230/330	* Support Intel [®] Atom 230/330 CPU * Support FSB Frequency 533MHz
Memory Socket	* 240-pin DDR2 DIMM module socket x 2 * Support Dual channel DDR2 533MHz RAM Module and which is expandable to 4GB.
Expansion Slots	* PCI-Express x1 slot 1pcs * 32-bit PCI slot 2pcs
Integrate IDE and Serial ATA2	* One PCI IDE controller that supports PCI Bus Mastering, ATA PIO/DMA and the ULTRA DMA 33/66/100 functions that deliver the data transfer rate up to 100 MB/s; two Serial ATA2 ports each provides 3.0 Gb /sec data transfer rate.
Integrated VGA	* Integrated Graphic Media Accelerator 950 * DirectX 9.0C compliant 2D/3D graphics processor
LAN	* Integrated Realtek RTL 8102EL PCI 10/100 LAN chip * Support Fast Ethernet LAN function of providing 10Mb / 100Mb data transfer rate
HD Audio	* Realtek ALC662 HD 6-CH Audio Codec integrated * Support 6-CH 3D surround & Positioning Audio * Audio driver and utility included
BIOS	* Award 8MB SPI Flash ROM
Multi I/O	* PS/2 keyboard and PS/2 mouse connectors * Floppy disk drive connector x1 * Parallel header x1 * Serial port x1 * D-Sub 15-pin VGA Conn. * USB 2.0 connector x 4, headers x4 * Audio connector x1 (Line-in, Line-out, MIC)

1-3 Item Checklist

- ✓ Intel® 945GC Platform Processor Chipset based motherboard
- ✓ Cable for IDE
- ✓ CD for motherboard utilities
- ✓ Cable for Serial ATA Port
- ✓ Intel® 945GC Platform Processor Chipset motherboard User’s Manual
- ✓ Back panel

1-4 Layout Diagram & Jumper Setting

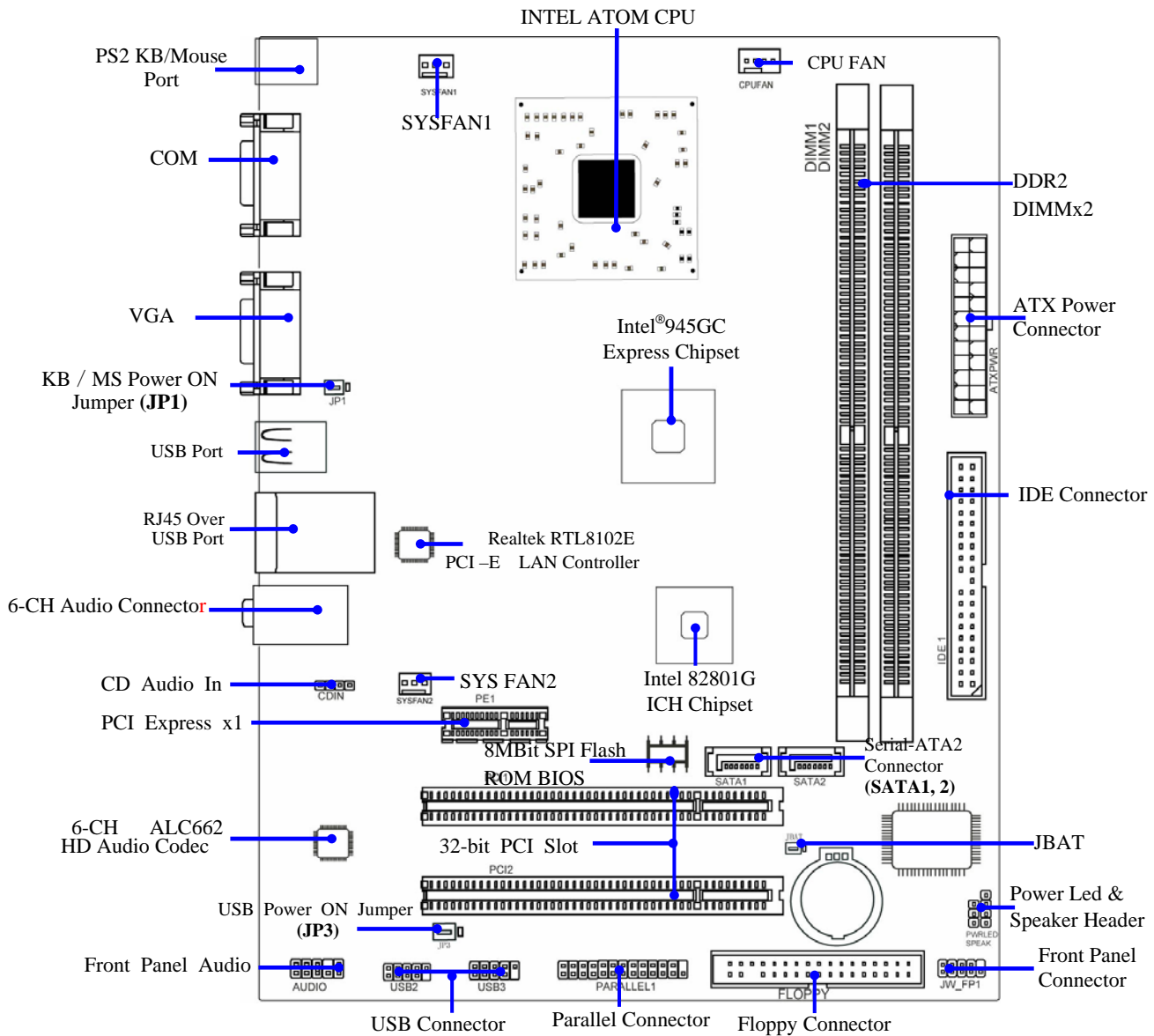

Chapter 2

Hardware Installation

2-1 Install Memory

This motherboard provides two 240-pin DDR2 DUAL INLINE MEMORY MODULES (DIMM) socket for DDR2 memory expansion available from minimum memory volume of 128MB to maximum memory volume of 4GB DDR2 DIMM.

Valid Memory Configurations

Bank	240-Pin DIMM	PCS	Total Memory
Bank 0, 1 (DIMM1)	DDR2 533	X1	128MB~2GB
Bank 2, 3 (DIMM2)	DDR2 533	X1	128MB~2GB
Total	Memory (Max.4GB)	2	128MB~4GB

Recommend DIMM Module Combination

1. *One DIMM Module ---Plug in DIMM1*
2. *Two DIMM Modules---Plug in DIMM1 and DIMM2 for Dual channel function*

Install DDR2 SDRAM modules to your motherboard is not difficult, you can refer to figure below to see how to install a 240-Pin DDR2 533 SDRAM module.

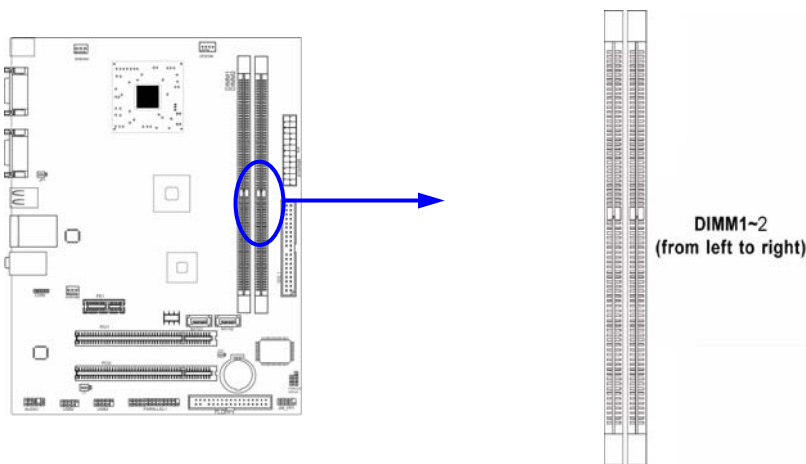

NOTE! When you install DIMM module fully into the DIMM socket the eject tab should be locked into the DIMM module very firmly and fit into its indentation on both sides.

2-2 Expansion Cards

The Intel[®] 945GC motherboard series offer two 32-bit PCI slots guarantee the rich connectivity for the I/O of peripherals. And one PCI Express x1 I/O slot. The motherboards are designed of tackling the profuse multimedia requirements nowadays.

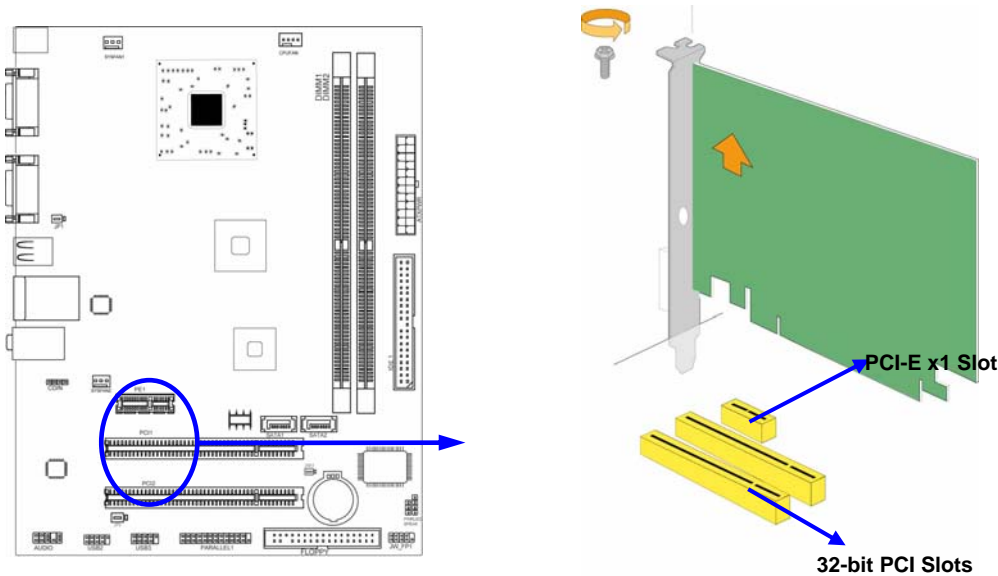

Chapter 3

Connectors, Headers & Jumpers Setting

3-1 Connectors

(1) Power Connector (20-pin block): ATXPWR

ATX Power Supply connector: This is a new defined 20-pins connector that usually comes with ATX case. The ATX Power Supply allows using soft power on momentary switch that connect from the front panel switch to 2-pins Power On jumper pole on the motherboard. When the power switch on the back of the ATX power supply turned on, the full power will not come into the system board until the front panel switch is momentarily pressed. Press this switch again will turn off the power to the system board.

** If you intend to use a PSU with 20-pin power plugs, make sure that the 20-pin power plug can provide at least 15A on +12V and the power supply unit has a minimum power rating of 350W. The system may become unstable or may not boot up if the power is inadequate.

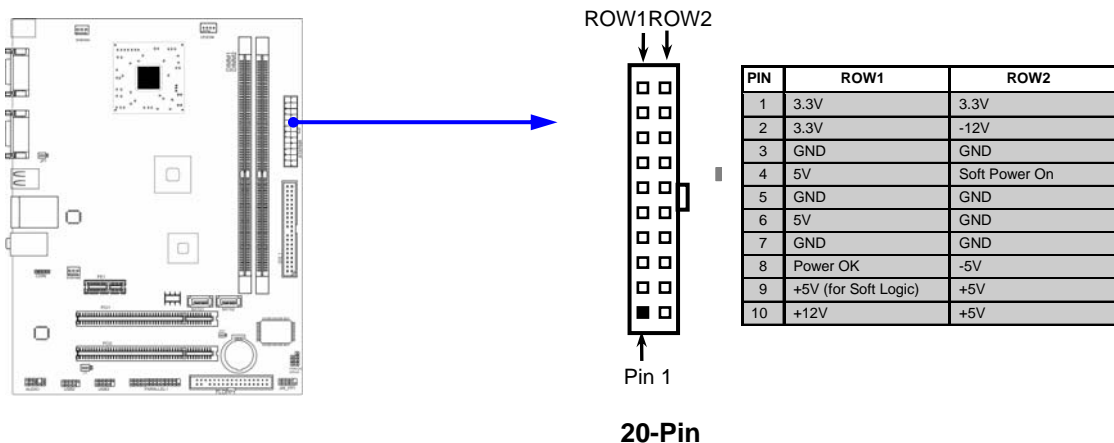

(2) **PS/2 Mouse & PS/2 Keyboard Connector: KB**

The connectors are for PS/2 keyboard and PS/2 Mouse.

(3) **USB Port connector: USB1, UL1**

The connectors are 4-pin connectors that connect USB devices to the system board.

(4) **LAN Port connector: UL1**

This connector is standard RJ45 connector for Network.

The USBLAN1 support 10M/100Mbps data transfer rate.

(5) **Audio Line-In, Lin-Out, MIC Connector: SURROUND1**

This Connector are 3 phone Jack for LINE-OUT, LINE-IN, MIC

Line-out: (GREEN) Audio output to speaker

Line-in: (BLUE) Audio input to sound chip

MIC: (PINK) Microphone Connector

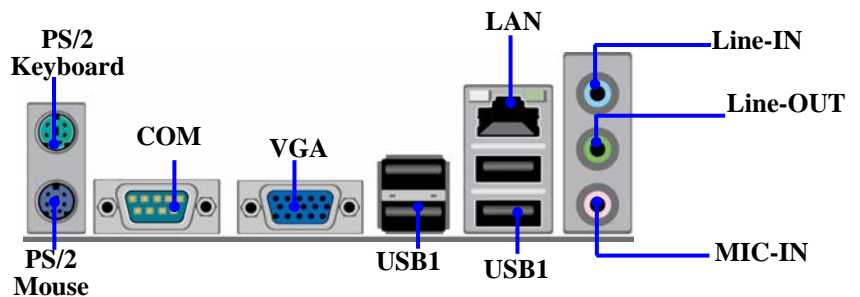
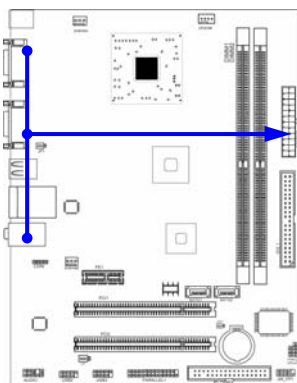

(6) **Floppy drive Connector (34-pin block): FLOPPY**

This connector supports the provided floppy drive ribbon cable. After connecting the single plug end to motherboard, connect the two plugs at other end to the floppy drives.

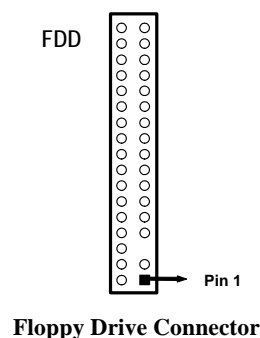
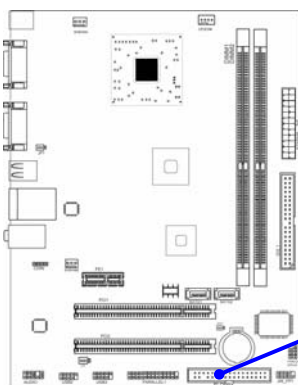

(7) **Primary IDE Connector (40-pin block): IDE**

This connector connects to the next set of Master and Slave hard disks. Follow the same procedure described for the primary IDE connector. You may also configure two

hard disks to be both Masters using one ribbon cable on the primary IDE connector and another ribbon cable on the secondary IDE connector.

- Two hard disks can be connected to each connector. The first HDD is referred to as the “Master” and the second HDD is referred to as the “Slave”.
- For performance issues, we strongly suggest you don’t install a CD-ROM or DVD-ROM drive on the same IDE channel as a hard disk. Otherwise, the system performance on this channel may drop.

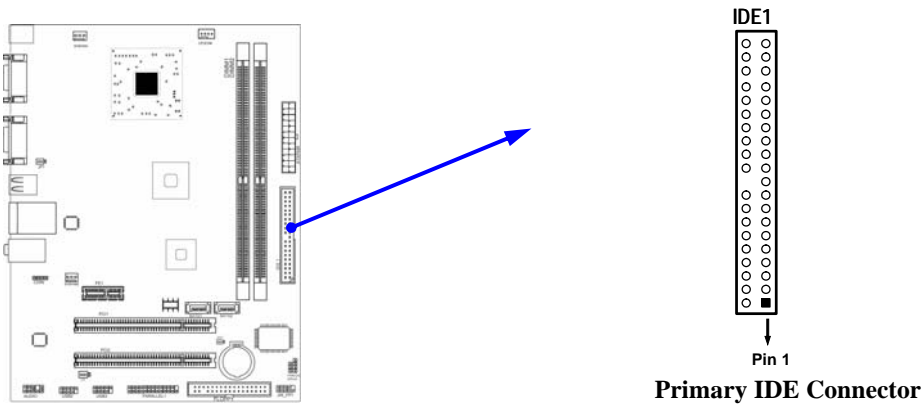

(8) Serial-ATA Port connector: SATAII 1 / SATAII 2

These connectors support the provided Serial ATA and Serial ATA2 IDE hard disk cable to connecting the motherboard and serial ATA hard disk.

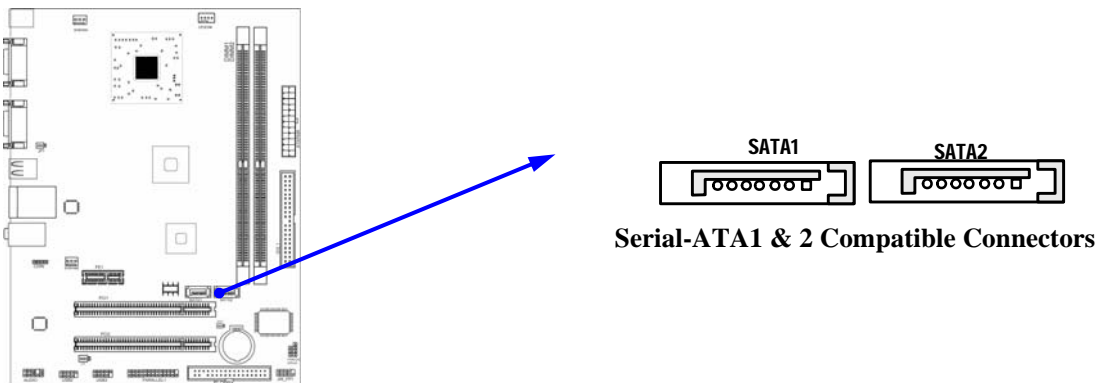

(9) Serial COM Port: COM1

COM1 is the 9-pin connector. The On-board serial port can be disabled through BIOS SETUP.

(10) VGA Connector (15-pin D-Sub) Connector: VGA

VGA is the 15-pin D-Subminiature female connector for display monitor.

3-2 Headers

(1) Line-Out/MIC Header for Front Panel (9-pin): AUDIO

This header is connected to Front Panel Line-out, MIC connector with cable.

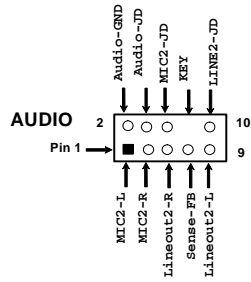
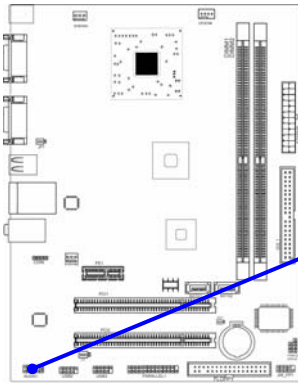

Line-Out, MIC Headers

(2) USB Port Headers (9-pin) : USB2 / USB3

These headers are used for connecting the additional USB port plug. By attaching an option USB cable, your can be provided with two additional USB plugs affixed to the back panel.

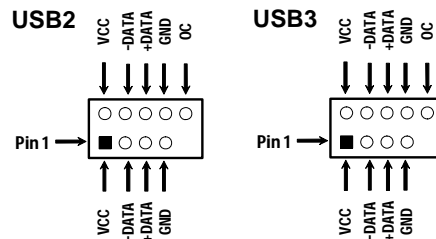
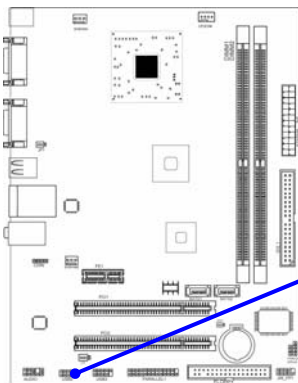

USB Port Headers

(3) Speaker connector: SPEAK

This 4-pin connector connects to the case-mounted speaker. See the figure below.

(4) Power LED: PWR LED

The Power LED is light on while the system power is on. Connect the Power LED from the system case to this pin.

(5) IDE Activity LED: HD LED

This connector connects to the hard disk activity indicator light on the case.

(6) Reset switch lead: RESET

This 2-pin connector connects to the case-mounted reset switch for rebooting your computer without having to turn off your power switch. This is a preferred method of rebooting in order to prolong the life of the system's power supply. See the figure below.

(7) Power switch: PWR BTN

This 2-pin connector connects to the case-mounted power switch to power ON/OFF the system.

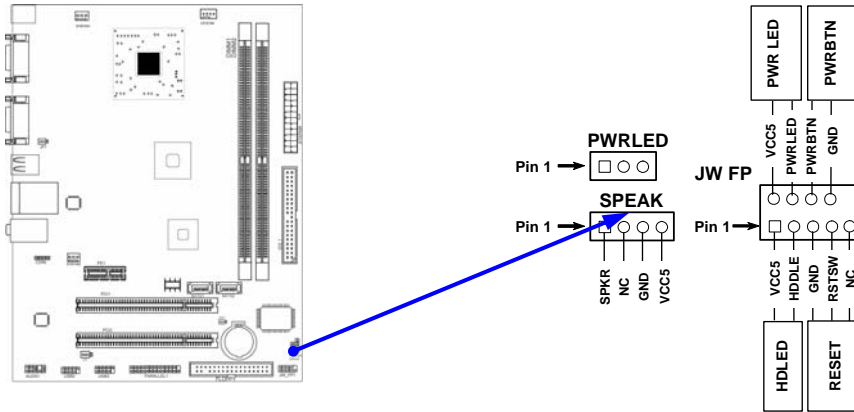

System Case Connections

(8) FAN Power Headers: SYSFAN1, SYSFAN2 (3-pin), CPUFAN (3-pin)

These connectors support cooling fans of 350mA (4.2 Watts) or less, depending on the fan manufacturer, the wire and plug may be different. The red wire should be positive, while the black should be ground. Connect the fan's plug to the board taking into consideration the polarity of connector.

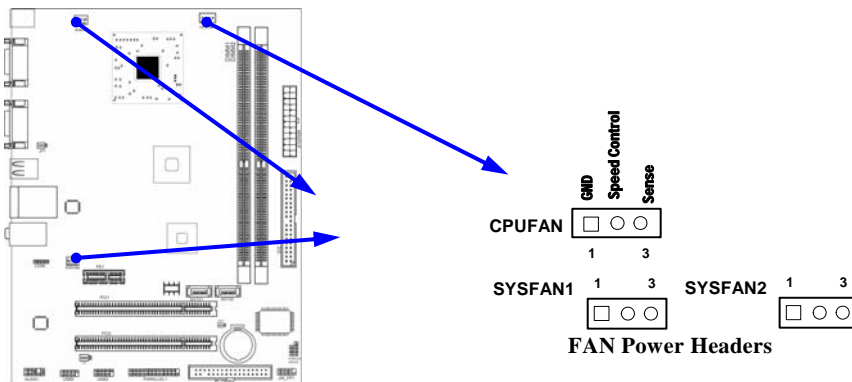

FAN Power Headers

(9) CD Audio-In Headers (4-pin): CDIN

CDIN are the connectors for CD-Audio Input signal. Please connect it to CD-ROM CD-Audio output connector.

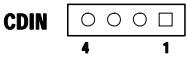
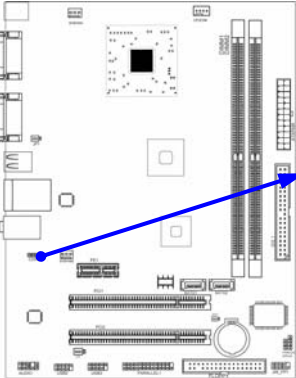

CD Audio-In Headers

(10) Parallel Port header (25-pin): PARALLEL

The On-board Parallel Port can be disabled through the BIOS SETUP. .

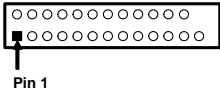
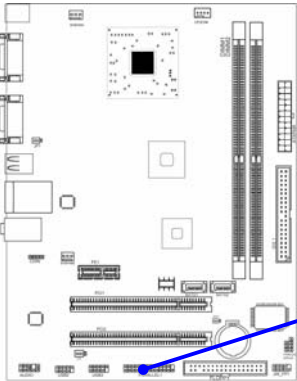

PARALLEL Connector

Chapter 4 USEFUL HELP

4-1 HOW TO UPDATE BIOS

STEP 1. Prepare a [boot floppy disc](#). (You may make one by click START click RUN type SYS A: [click OK](#))

STEP 2. Download upgrade tools and the latest BIOS files of the motherboard from official website and then make a copy of it to your bootable [floppy](#) disk after decompressing these files

STEP 3. Insert the disk into A: start your computer and then type in “A:\xxxxxx.BAT”(xxxxxxx being the file name of the latest BIOS)

STEP 4. Type Enter to update and flash the BIOS. The system will restart automatically when BIOS is upgraded.

4-2 Trouble Shooting

Problem	Solution
No power to the system to the all power light don't illuminate, fan inside power supply doesn't turn on.	1. Make sure power cable is security plugged in. 2. Replace cable. 3. Contact technical support.
System inoperative. Keyboard lights are on , power indicator lights are lit, and hard drive is spinning.	Using ever pressure on both ends of the DIMM , press down firmly until the module snaps into places.
System doesn't boot from hard disk drive, can be booted from optical drive.	1. Check cable running from disk to disk controller board. .Make sure both ends are securely plugged in, check the drive type in the standard CMOS setup. 2. Backing up the hard drive is extremely important .All hard disks are capable of breaking down at any time.
System only boots from optical drive .Hard disk can be read and applications can be used but booting from hard disk is impossible.	1. Back up date and applications files. 2. Reformat the hard drive. Reinstall applications and date using backup disks.
Screen message says “Invalid Configuration” or “CMOS Failure”	Review system's equipment .Make sure correct information on is in setup.
Can not boot system after installing second hard drive.	1. Set master /slave jumpers correctly. 2. Run SETUP program and select correct drive types. Call the drive manufacture for compatibility with other drives.