

TECHNICAL MANUAL
Of
INTEL 945GC
Based
Mini-ITX M/B For ATOM Processor

NO.G03-NC91-F

Rev2.0

Release date: Nov. , 2008

Trademark:

* Specifications and Information contained in this documentation are furnished for information use only, and are subject to change at any time without notice, and should not be construed as a commitment by manufacturer.

Environmental Protection Announcement

Do not dispose this electronic device into the trash while discarding. To minimize pollution and ensure environment protection of mother earth, please recycle.



TABLE OF CONTENT

USER'S NOTICE	iii
MANUAL REVISION INFORMATION	iii
ITEM CHECKLIST	iii
CHAPTER 1 INTRODUCTION OF INTEL CHIPSET MOTHERBOARD	
1-1 FEATURE OF MOTHERBOARD	1
1-1-1 SPECICAL FEATURE OF MOTHERBOARD	2
1-2 SPECIFICATION	3
1-3 LAYOUT DIAGRAM & JUMPER SETTING	3
CHAPTER 2 HARDWARE INSTALLATION	
2-1 JUMPER SETTING	6
2-2 CONNECTORS AND HEADERS	7
2-2-1 CONNECTORS	7
2-2-2 HEADERS	8
CHAPTER 3	
3-1 ENTERING SETUP	12
3-2 GETTING HELP	13
3-3 THE MAIN MENU	13
3-4 ADVANCED BIOS FEATURES	16
3-5 INTERGRATED PERIPHERALS	19
3-6 PC HEALTH STATUS	20
3-7 POWER MANAGEMENT SETTING	22
3-8 MISCELLANEOUS CONFIGURATION	24

USER'S NOTICE

COPYRIGHT OF THIS MANUAL BELONGS TO THE MANUFACTURER. NO PART OF THIS MANUAL, INCLUDING THE PRODUCTS AND SOFTWARE DESCRIBED IN IT MAY BE REPRODUCED, TRANSMITTED OR TRANSLATED INTO ANY LANGUAGE IN ANY FORM OR BY ANY MEANS WITHOUT WRITTEN PERMISSION OF THE MANUFACTURER.

THIS MANUAL CONTAINS ALL INFORMATION REQUIRED TO USE INTEL 945GM CHIPSET MOTHER-BOARD SERIES AND WE DO ASSURE THIS MANUAL MEETS USER'S REQUIREMENT BUT WILL CHANGE, CORRECT ANY TIME WITHOUT NOTICE. MANUFACTURER PROVIDES THIS MANUAL "AS IS" WITHOUT WARRANTY OF ANY KIND, AND WILL NOT BE LIABLE FOR ANY INDIRECT, SPECIAL, INCIDENTAL OR CONSEQUENTIAL DAMAGES (INCLUDING DAMAGES FOR LOSS OF PROFIT, LOSS OF BUSINESS, LOSS OF USE OF DATA, INTERRUPTION OF BUSINESS AND THE LIKE).

PRODUCTS AND CORPORATE NAMES APPEARING IN THIS MANUAL MAY OR MAY NOT BE REGISTERED TRADEMARKS OR COPYRIGHTS OF THEIR RESPECTIVE COMPANIES, AND THEY ARE USED ONLY FOR IDENTIFICATION OR EXPLANATION AND TO THE OWNER'S BENEFIT, WITHOUT INTENT TO INFRINGE.

Manual Revision Information

Reversion	Revision History	Date
2.0	Second Edition	November, 2008

Item Checklist

- Motherboard
- Cable(s)
- CD for motherboard utilities
- Motherboard User's Manual
- Back panel

Chapter 1

Introduction of the Motherboard

1-1 Feature of motherboard

- * Intel 945GC chipset and ICH7 chipset.
- * Onboard Intel ATOM CPU, with low power consumption never denies high performance.
- * Support FSB 533MHz.
- * Support DDRII 400/533MHz up to 2GB.
- * Onboard RTL 8102E **Megabit** Ethernet LAN (only for NC91-230-LF).
- * Onboard RTL 8111C Gigabit Ethernet LAN (only for NC91-330-LF).
- * Integrated Realtek ALC662 6-Channel Audio CODEC.
- * Support USB2.0 data transport demands .

1-2 Specification

Spec	Description
Design	* Mini ITX form factor 4 layers PCB size: 17.0x17.0cm
Chipset	* Intel 945GC Northbridge chipset * Intel 82801G Southbridge chipset
Embedded CPU	* Support FSB533 * Low Power Consumption * ATOM CPU
Memory Socket	* 240-pin DDRII DIMM socket x1 * Support DDRII 400MHz /DDRII 533MHz system Modules DDR memory * Expandable to 2GB.
Expansion Slots	* 32-bit PCI slot x 1pcs
Integrate IDE	* One PCI IDE controller that supports PCI Bus Mastering, ATA PIO/DMA and the ULTRA DMA 133/100/66 functions that deliver the data transfer rate up to 100 MB/s;
LAN	* Integrated Realtek RTL8111C PCI-E LAN (only for NC91-330-LF). * Support Fast Ethernet LAN function of providing 10Mb/100Mb/1000Mb (only for NC91-330-LF)Ethernet data transfer rate * Integrated Realtek RTL8102E PCI-E LAN (only for NC91-230-LF). * Support Fast Ethernet LAN function of providing 10Mb/100Mb (only for NC91-230-LF)Ethernet data transfer rate

Audio	<ul style="list-style-type: none"> * Realtek ALC662 6 channel Audio Codec integrated * Audio driver and utility included
BIOS	<ul style="list-style-type: none"> * Award 8MB SPI Flash ROM

1-3 Layout Diagram & Jumper Setting

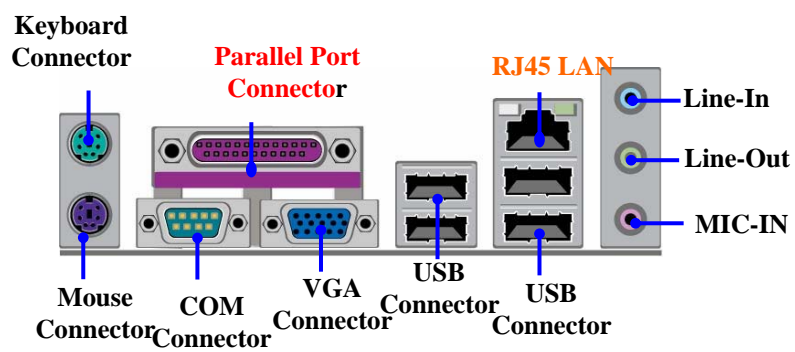

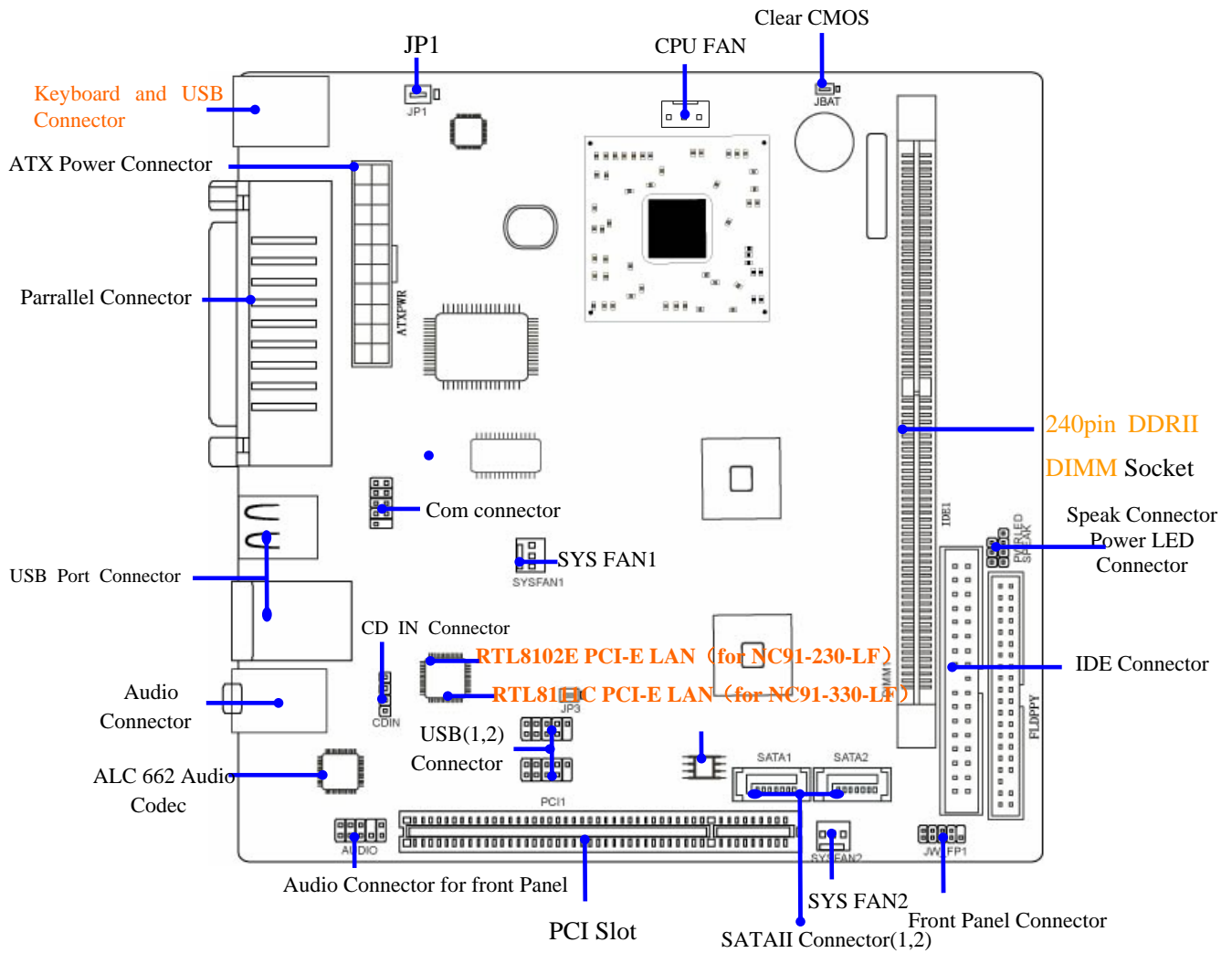

Jumper

Jumper	Name	Description	Page
JBAT	CMOS RAM Clear Function Setting	3-pin Block	p.6
JP1	KB/USB Power On Function Setting	3-pin Block	P.6
JP3	USB1/2 Power On Function Setting	3-pin Block	P.7

Connectors

Connector	Name	Description	Page
USB1,USB2	USB Port Connector	4-pin Connector	p.7
UL3	RJ45 LAN Connector		p.7
VGA CN	VGA Port Connector	D-sub15-pin Female	p.7
CN4	Line-Out /MIC/Line-In Audio Connector	3 Phone Jack	p.7
PS2 KB/MS	PS2 Keyboard & Mouse Connector		p.7
SATA1,2	Serial ATA Connectors		p.7

Headers

Header	Name	Description	Page
USB1,USB2	USB2.0 Port Headers	9-pin Block	p.8
IDE	40-Pin IDE Connector	40-pin IDE Block	p.8
CPUFAN, SFAN1/2	FAN Speed Headers	3-pin Block	P.11
JW_FP1 (PWR LED/ IDE LED/ /Power Button /Reset)	Front Panel Headers (PWR LED/ IDE LED/ /Power Button /Reset)	9-pin Block	P.9

Chapter 2

2-1 Jumper Setting

(1) Clear CMOS (3-pin): JBAT

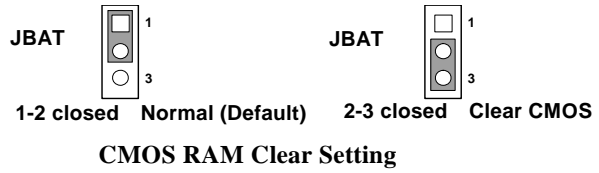
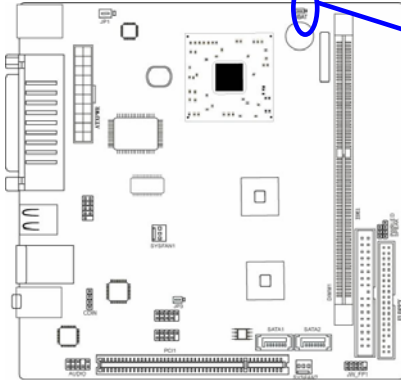

(2) JP1 KB/USB Power On Function Setting

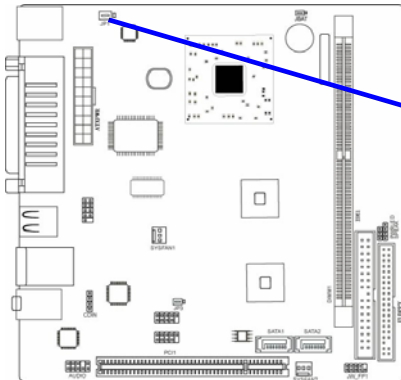

(3) JP3 USB1/2 Power On Function Setting

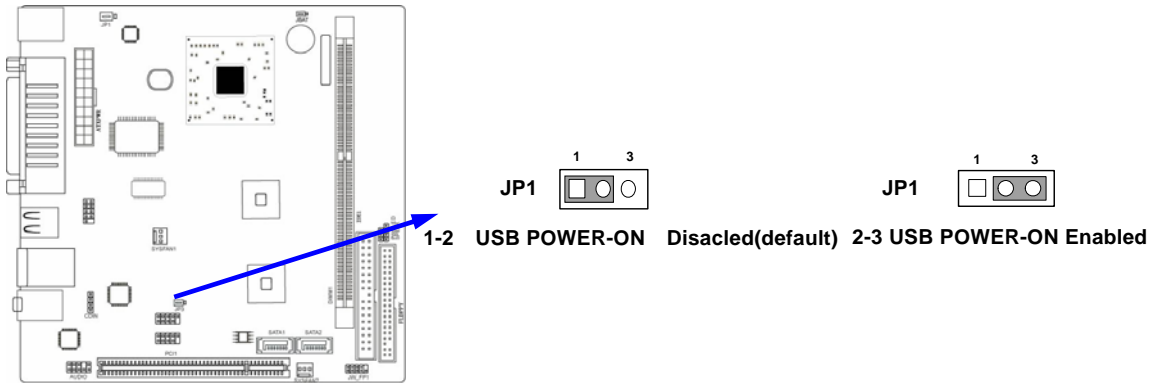

2-2 Connectors and Headers

2-2-1 Connectors

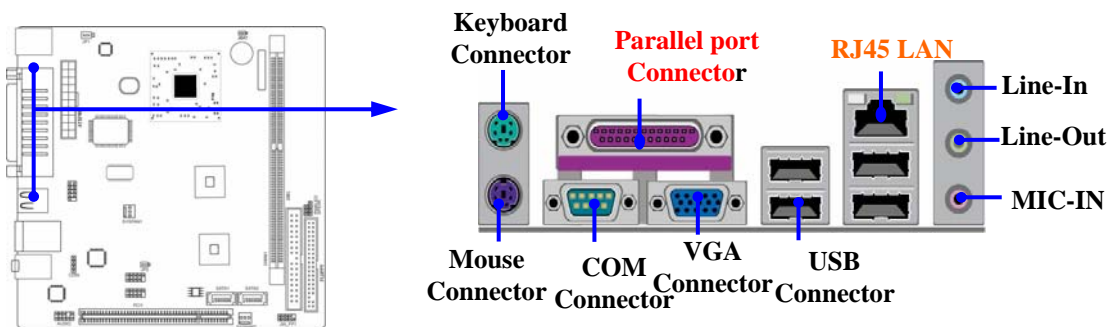

2-5-2 Headers

(1) USB Port Headers (9-pin):

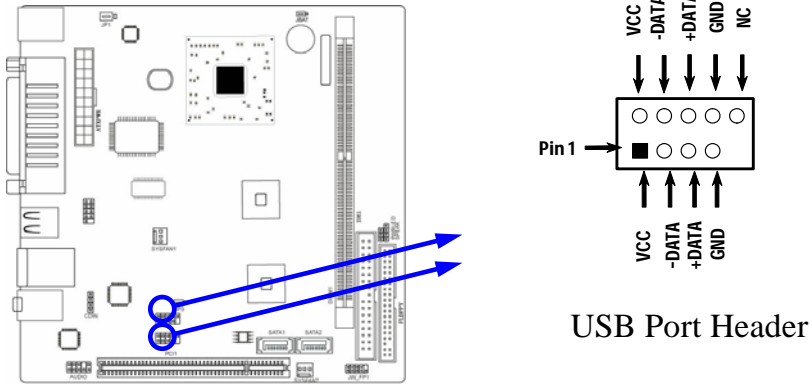

(2) IDE Connector:

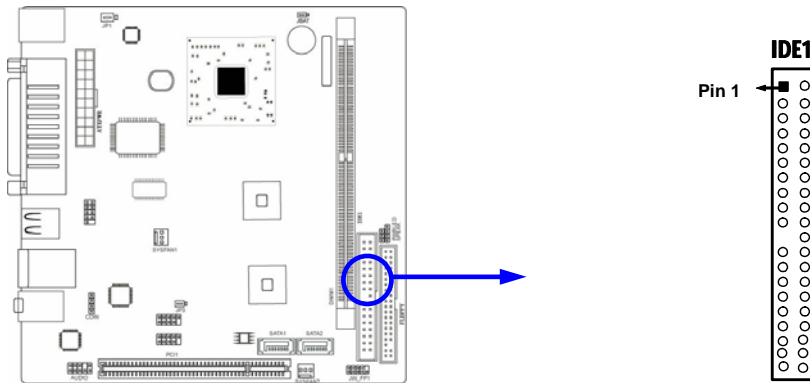

(3) Power switch: FRONT PANEL

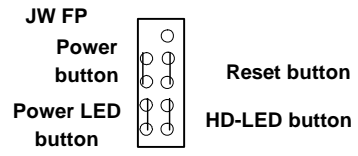
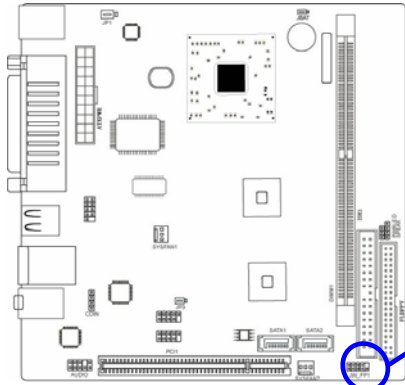

System Case Connections

(4) Serial ATA Connector (7-pin female): SATAII1/SATAII2

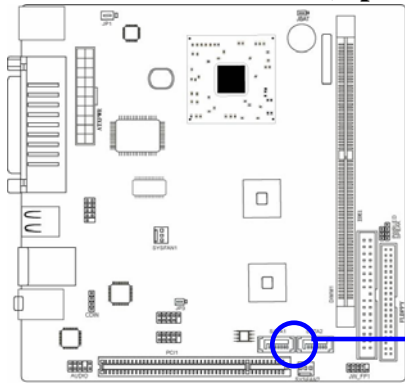

Serial-ATA2 Port Connector

(5) Line-Out, MIC-In Header (9-pin): AUDIO for front Panel

This header connects to Front Panel Line-out, MIC-In connector with cable.

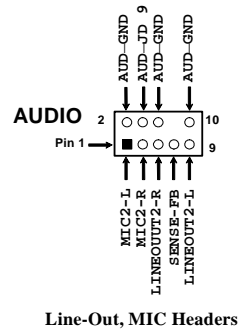
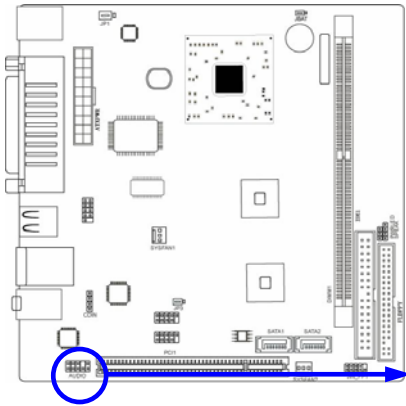

(6) CD Audio-In Headers (4-pin): CDIN

CDIN are the connectors for CD-Audio Input signal. Please connect it to CD-ROM CD-Audio output connector.

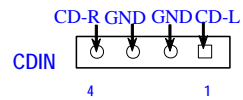
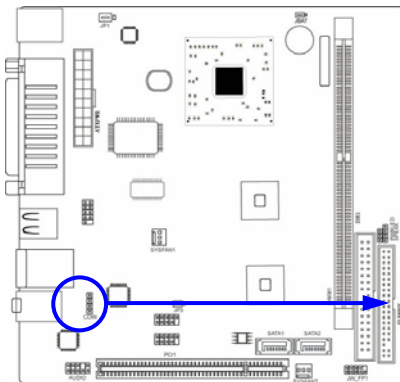

(7) FAN Speed Headers (3-pin): CPUFAN, SFAN1/SFAN2

These connectors support cooling fans of 350mA (4.2 Watts) or less, depending on the fan manufacturer, the wire and plug may be different. The red wire should be positive, while the black should be ground. Connect the fan's plug to the board taking into consideration the polarity of connector.

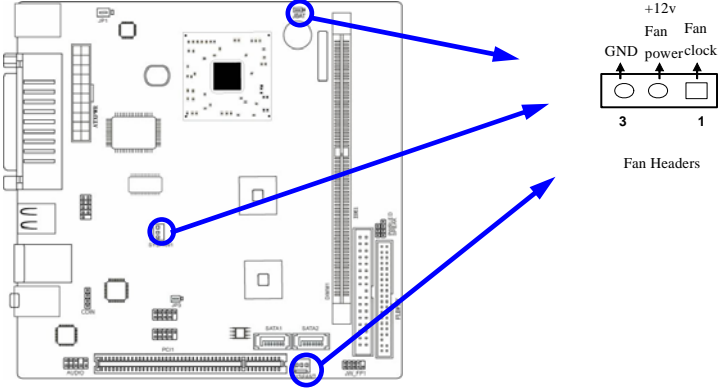

Chapter 3

Introducing BIOS

The BIOS is a program located on a Flash Memory on the motherboard. This program is a bridge between motherboard and operating system. When you start the computer, the BIOS program will gain control. The BIOS first operates an auto-diagnostic test called POST (power on self test) for all the necessary hardware, it detects the entire hardware device and configures the parameters of the hardware synchronization. Only when these tasks are completed done it gives up control of the computer to operating system (OS). Since the BIOS is the only channel for hardware and software to communicate, it is the key factor for system stability, and in ensuring that your system performance as its best.

In the BIOS Setup main menu of Figure 3-1, you can see several options. We will explain these options step by step in the following pages of this chapter, but let us first see a short description of the function keys you may use here:

- Press <Esc> to quit the BIOS Setup.
- Press ↑↓←→ (up, down, left, right) to choose, in the main menu, the option you want to confirm or to modify.
- Press <F10> when you have completed the setup of BIOS parameters to save these parameters and to exit the BIOS Setup menu.
- Press Page Up/Page Down or +/- keys when you want to modify the BIOS parameters for the active option.

3-1 Entering Setup

Power on the computer and by pressing immediately allows you to enter Setup.

If the message disappears before you respond and you still wish to enter Setup, restart the system to try again by turning it OFF then ON or pressing the “RESET” button on the system case. You may also restart by simultaneously pressing <Ctrl>, <Alt> and <Delete> keys. If you do not press the keys at the correct time and the system does not boot, an error message will be displayed and you will again be asked to

Press <F1> to continue, <Ctrl-Alt-Esc> or to enter Setup

3-2 Getting Help

Main Menu

The on-line description of the highlighted setup function is displayed at the bottom of the screen.

Status Page Setup Menu/Option Page Setup Menu

Press F1 to pop up a small help window that describes the appropriate keys to use and the possible selections for the highlighted item. To exit the Help Window, press <Esc>.

3-3 The Main Menu

Once you enter Award® BIOS CMOS Setup Utility, the Main Menu (Figure 3-1) will appear on the screen. The Main Menu allows you to select from fourteen setup functions and two exit choices. Use arrow keys to select among the items and press <Enter> to accept or enter the sub-menu.

Phoenix - AwardBIOS CMOS Setup Utility

Standard CMOS Features	Miscellaneous Control
Advanced BIOS Features	Load Optimized Defaults
Advanced Chipset Features	Load standard Defaults
Integrated Peripherals	Set Supervisor password
Power Management Setup	Set user password
PnP/PCI Configurations	Save & Exit Setup
PC Health Status	Exit Without Saving
Esc : Quit F9 : Menu in BIOS ↑↓→← : Select Item	
F10 : Save & Exit Setup	

Figure 3-1

Standard CMOS Features

Use this Menu for basic system configurations.

Advanced BIOS Features

Use this menu to set the Advanced Features available on your system.

Advanced Chipset Features

Use this menu to change the values in the chipset registers and optimize your system's performance.

Integrated Peripherals

Use this menu to specify your settings for integrated peripherals.

Power Management Setup

Use this menu to specify your settings for power management.

Miscellaneous Control

Use this menu to specify your settings for **Miscellaneous Control**.

PC Health Status

This entry shows your PC health status.

Power User Overclock Settings

Use this menu to specify your settings (frequency, Voltage) for overclocking demand

CPU Thermal Throttling Setting

The selection is set for activating the active CPU Thermal Protection by flexible CPU loading adjustment in the arrange of temperature you define.

Load Optimized Defaults

Use this menu to load the BIOS default values these are setting for optimal performances system operations for performance use.

Password Settings

This entry for setting Supervisor passwds and User password

Save & Exit Setup

Save CMOS value changes to CMOS and exit setup.

Exit Without Saving

Abandon all CMOS value changes and exit setup.

3-4 Advanced BIOS Features

Phoenix - AwardBIOS CMOS Setup Utility

Advanced BIOS Features

Virus Warning	Disabled	Item Help	
CPU L3 Cache	Enabled		
CPU Feature	Press Enter	Menu Level >	
Hard Disk Boot Priority	Press Enter		
Hyper-Threading Technology	Enabled		
Quick power on self Test	Enabled		
First Boot Device	Removable		
Second Boot Device	Hard Disk		
Third Boot Device	CDROM		
Boot other Device	Enabled		
Boot other Device	Enabled		
Boot Up NumLock Status	On		
Typematic Rate Setting	Disabled		
Typematic Rate (Chars/Sec)	6		
Typematic Delay (Msec)	250		
Security Option	Setup		
APIC Mode	Enabled		
MPS Version Control For OS	1.4		
OS Select For DRAM > 64MB	Non-OS2		
HDD S.M.A.R.T. Capability	Disabled		
Report No FDD For windows	Yes		
Limit CPULD Maxval	Disabled		
C1E Function	Enabled		
Execute Disabled Bit	Enabled		
↑↓→← Move Enter:Select +/-/PU/PD:Value F10:Save ESC:Exit F1:General Help F5:Previous Values F6:Optimized Defaults F7:Standard Defaults			

Hard Disk Boot Priority

The selection is for you to choose the hard disk drives priorities to boot from.

Virus Warning

The selection Allow you to choose the VIRUS Warning feature for IDE Hard Disk boot sector protection. If this function is enabled and someone attempt to write data into this area, BIOS will show a warning message on screen and alarm beep.

Disabled (default) No warning message to appear when anything attempts to access the boot sector or hard disk partition table.

Enabled Activates automatically when the system boots up causing a warning message to appear when anything attempts to access the boot sector of hard disk partition table.

CPU Internal Cache

The default value is Enabled.

Enabled (default) Enable cache

Disabled Disable cache

Note: The internal cache is built in the processor.

External Cache

Choose Enabled or Disabled. This option enables the Level 2 cache memory.

Quick Power On Self-Test

This category speeds up Power On Self Test (POST) after you power on the computer. If this is set to Enabled, BIOS will shorten or skip some check items during POST.

Enabled (default) Enable quick POST

Disabled Normal POST

First/Second/Third Boot Device

The BIOS attempts to load the operating system from the devices in the sequence selected in these items. The settings are Floppy, LS/ZIP, HDD-0/HDD-1/HDD-3, SCSI, CDROM, LAD and Disabled.

Boot Up Floppy Seek

During POST, BIOS will determine if the floppy disk drive installed is 40 or 80 tracks. 360K type is 40 tracks while 760K, 1.2M and 1.44M are all 80 tracks.

Boot Up NumLock Status

The default value is On.

On (default) Keypad is numeric keys.

Off Keypad is arrow keys.

Gate A20 Option

Normal The A20 signal is controlled by keyboard controller or chipset hardware.

Fast (default) The A20 signal is controlled by port 92 or chipset specific method.

Typematic Rate Setting

Keystrokes repeat at a rate determined by the keyboard controller. When enabled, the typematic rate and typematic delay can be selected. The settings are: Enabled/Disabled.

Typematic Rate (Chars/Sec)

Sets the number of times a second to repeat a keystroke when you hold the key down. The settings are: 6, 8, 10, 12, 15, 20, 24, and 30.

Typematic Delay (Msec)

Sets the delay time after the key is held down before beginning to repeat the keystroke. The settings are 250, 500, 750, and 1000.

Security Option

This category allows you to limit access to the system and Setup, or just to Setup.

System The system will not boot and access to Setup will be denied if the correct password is not entered at the prompt.

Setup (default) The system will boot, but access to Setup will be denied if the correct password is not entered prompt.

HDD S.M.A.R.T Capability

This option allow you to enable the HDD S.M.A.R.T Capability (Self-Monitoring, Analysis and Reporting Technology) . You can choose from Enabled and Disabled.

MPS Version Control For OS 1.4

This option is only valid for multiprocessor motherboards as it specifies the version of the Multiprocessor Specification (MPS) that the motherboard will use.

OS Select For DRAM > 64MB

Allows OS2[®] to be used with >64MB or DRAM. Settings are Non-OS/2 (default) and OS2. Set to OS/2 if using more than 64MB and running OS/2[®].

3-5 Intergrated peripherals

Phoenix - AwardBIOS CMOS Setup Utility
Intergrated peripheral

Onboard IDE Function	Press Enter	Item Help
Onboard Device Function	Press Enter	
Onboard Superio Funtion	Press Enter	Menu Level >>
PWR Status after PWE Failure	Press Enter	
Init Display First	PCI Slot	
↑↓← Move Enter:Select +/-/PU/PD:Value F10:Save ESC:Exit F1:General Help F5:Previous Values F6:Optimized Defaults F7:Standard Defaults		

Phoenix - AwardBIOS CMOS Setup Utility
OnBoard Device Function

Onboard PCIE Lan Controller	Auto	Item Help
Onboard PCIE LAN Bootrom	Disabled	
High Definition Audio	Enabled	Menu Level >>
USB Host Controller	Enabled	
USB 2.0 Function	Enabled	
USB keyboard Legacy Support	Disabled	
USB Mouse Legacy Support	Enabled	
↑↓← Move Enter:Select +/-/PU/PD:Value F10:Save ESC:Exit F1:General Help F5:Previous Values F6:Optimized Defaults F7:Standard Defaults		

Onboard HD Audio

This item allows you to decide to enable/disable the chipset family to support HD Audio. The settings are: Enabled, Disabled.

Onboard PCIE LAN Bootrom

Decide whether to invoke the boot ROM of the onboard LAN chip.

3-6 PC Health Status

This section shows the Status of you CPU, Fan, and Warning for overall system status. This is only available if there is Hardware Monitor onboard.

Phoenix - AwardBIOS CMOS Setup Utility

PC Health Status

Shutdown Temperature	Enabled	Item Help
CPU Thermal-Throttling	Press Enter	
CPU Thermal-Throttling Temp	70°C	Menu Level >
CPU Thermal-Throttling Duty	50.00%	
CPU Thermal-Throttling Beep	Enabled	
Show PCHealth in Post	Enabled	
Smart fan configurations	Press Enter	
VCC 3V	3.42V	
Vcore	1.10V	
+1.5V	1.51V	
+5V	4.96V	
+12V	12.14V	
5VSB	5.08V	
VDIM	1.84V	
VBAT	3.17V	
CPU Temperature	67°C/152F	
SYS Temperature	44°C/113F	
CPUFAN Speed	0 RPM	
↑↓→← Move Enter:Select +/-/PU/PD:Value F10:Save ESC:Exit F1:General Help F5:Previous Values F6:Optimized Defaults F7:Standard Defaults		

Show PC Health in Post

During Enabled, it displays information list below. The choice is either Enabled or Disabled

CPU Smart FAN Configurations

CPU Full-Speed Temp

This item allows you setting the FAN works in full speed when the temperature over the value which out set. If the temperature below the value but over the Idle Temperature, the FAN will works over 60% of full speed, and the higher temperature will gain higher FAN speed, after over the temperature which this item setting, the FAN works in full speed.

CPU Idle Temp

This item allows you setting the FAN works in 60% of full speed, when the temperature lower than the temperature which you setting.

Current CPU Temperature/Current System Temp/Current FAN1, FAN2 Speed/Vcore/Vdd/3.3V/+5V/+12V/-12V/VBAT(V)/5VSB(V)

This will show the CPU/FAN/System voltage chart and FAN Speed.

SFAN Smart Mode:

There are three choose , Disabled, Formula 1, Formula 2.

Disabled: Fan setting full speed.

Formula 1: Fan working low speed, under temperature 2.

Formula 2: Fan stop when under temperature 2.

3-7 Power Management Setup

The Power Management Setup allows you to configure your system to most effectively save energy saving while operating in a manner consistent with your own style of computer use.

Phoenix - AwardBIOS CMOS Setup Utility

Power Management Setup

ACPI function	Enabled	Item Help	
Power Management	User Define		
Video off Method	V/H SyNC + BLANK	Menu Level >	
Video off in Suspend	Yes		
Suspend Type	Stop Grant		
Modem USE IRQ	3		
Suspend Mode	Disabled		
HDD Power Down	Disabled		
Soft-OFF by PWRBTN	Instant off		
Wake-up by PCI Card	Disabled		
Power on by ring	Disabled		
Wake-up by USB KB from S4	Disabled		
PS2 KB/MS Wake-up from s4-s5	Disabled		
Resume by alarm	Disabled		
Date of month alarm	0		
Time(hh:mm:ss) alarm	0:0:0		
PM Timer Reload Events	Press Enter		
PCI Express PM Function	Press Enter		
↑↓← Move Enter:Select +/-/PU/PD:Value F10:Save ESC:Exit F1:General Help F5:Previous Values F6:Optimized Defaults F7:Standard Defaults			

ACPI Function

This item allows you to Enabled/Disabled the Advanced Configuration and Power Management (ACPI). The settings are Enabled and Disabled.

HDD Power Down (Disabled)

The IDE hard drive will spin down if it is not accessed within a specified length of time. Options are from 1 Min to 15 Min and Disable.

Video Off Method

This determines the manner in which the monitor is blanked.

DPMS (default) Initial display power management signaling.

Blank Screen This option only writes blanks to the video buffer.

V/H SYNC+Blank This selection will cause the system to turn off the vertical and horizontal synchronization ports and write blanks to the video buffer.

.MODEM Use IRQ

If you want an incoming call on a modem to automatically resume the system from a power-saving mode, use this item to specify the interrupt request line (IRQ) that is used by the modem. You might have to connect the fax/modem to the motherboard Wake On Modem connector for this feature to work.

Soft-Off by PWRBTN

Under ACPI (Advanced Configuration and Power management Interface) you can create a software power down. In a software power down, the system can be resumed by Wake up Alarms. This item lets you install a software power down that is controlled by the power Button on your system. If the item is set to Instant-Off, then the power button causes a software power down. If the item is set to Delay 4 Sec, then you have to hold the power button down for four seconds to cause a software power down.

RTC Alarm Resume

When set to Enabled, additional fields become available and you can set the date (day of the month), hour, minute and second to turn on your system. When set to 0 (zero) for the day of the month, the alarm will power on your system every day at the specified time .

Date (of month)

You can choose which month the system will boot up. Set to 0, to boot every day.

Time (hh:mm:ss)

You can choose what hour, minute and second the system will boot up.

Note: If you have change the setting, you must let the system boot up until it goes to the operating system, before this function will work.

3-8 Miscellaneous Configuration

Phoenix - AwardBIOS CMOS Setup Utility

Miscellaneous Control

Auto Detect PCI Clock	Disabled	Item Help	
Spread Spectrum	Disabled		
Current Host/PCI Clock is	133/33MHz	Menu Level >	
Host/PCI Clock at Next Boot	133/33MHz		
Current DRAM Clock is	533MHz		
DRAM Clock at next Boot	BY SPD(DDR 533)		
CPU Vcore 7-shift	Normal		
VCC 1.05 Select	1.067v(default)		
NB VCCP Select	1.1213v(default)		
SB VCC Select	1.5080v(default)		
VCC 2.5V Select	2.5021v(default)		
VDIMM Select	1.863v(default)		
↑↓← Move Enter:Select +/-/PU/PD:Value F10:Save ESC:Exit F1:General Help			
F5:Previous Values F6:Optimized Defaults F7:Standard Defaults			

Reset Configuration Data

If you enable this item and restart the system, any Plug and Play configuration data stored in the BIOS Setup is cleared from memory.