

TECHNICAL MANUAL
Of
Intel 945GSE Express Chipset
&
Intel FW82801GBM ICH Chipset
Based
Mini-ITX M/B For ATOM Processor

NO.G03-NF32-F

Rev 1.0

Release date: July, 2009

Trademark:

* Specifications and Information contained in this documentation are furnished for information use only, and are subject to change at any time without notice, and should not be construed as a commitment by manufacturer.

Environmental Protection Announcement

Do not dispose this electronic device into the trash while discarding. To minimize pollution and ensure environment protection of mother earth, please recycle.



TABLE OF CONTENT

ENVIRONMENTAL SAFETY INSTRUCTION	iv
USER'S NOTICE	v
MANUAL REVISION INFORMATION	v
ITEM CHECKLIST	v
CHAPTER 1 INTRODUCTION OF THE MOTHERBOARD	
1-1 FEATURE OF MOTHERBOARD	1
1-2 SPECIFICATION.....	2
1-3 LAYOUT DIAGRAM	3
CHAPTER 2 HARDWARE INSTALLATION	
2-1 JUMPER SETTING	7
2-2 CONNECTORS AND HEADERS	9
2-2-1 CONNECTORS.....	9
2-2-2 HEADERS	10
CHAPTER 3	
3-1 ENTERNING SETUP	16
3-2 GETTING HELP	16
3-3 THE MAIN MENU.....	16
3-4 STANDARD CMOS FEATURES	18
3-5 ADVANCED BIOS FEATURES	20
3-5-1 CPU FEATURES	22
3-6 ADVANCED CHIPSET FEATURES	22
3-7 INTEGRATED PHERIPHRALS.....	24
3-7-1 ONBOARD IDE FUNCTION.....	24
3-7-2 ONBOARD DEVICE FUNCTION.....	26
3-7-3 ONBOARD SUPERIO FUNCTION	27
3-8 POWER MANAGEMENT SETUP	29
3-9 PNP/PCI CONFIGURATION	31
3-10 PC HEALTH STATUS.....	31
3-11 MISCELLANEOUS CONTROL	33
3-12 PASSWORD SETTING	33



Environmental Safety Instruction

- Avoid the dusty, humidity and temperature extremes. Do not place the product in any area where it may become wet.
- 0 to 60 centigrade is the suitable temperature. (The figure comes from the request of the main chipset)
- Generally speaking, dramatic changes in temperature may lead to contact malfunction and crackles due to constant thermal expansion and contraction from the welding spots' that connect components and PCB. Computer should go through an adaptive phase before it boots when it is moved from a cold environment to a warmer one to avoid condensation phenomenon. These water drops attached on PCB or the surface of the components can bring about phenomena as minor as computer instability resulted from corrosion and oxidation from components and PCB or as major as short circuit that can burn the components. Suggest starting the computer until the temperature goes up.
- The increasing temperature of the capacitor may decrease the life of computer. Using the close case may decrease the life of other device because the higher temperature in the inner of the case.
- Attention to the heat sink when you over-clocking. The higher temperature may decrease the life of the device and burned the capacitor.

USER'S NOTICE

COPYRIGHT OF THIS MANUAL BELONGS TO THE MANUFACTURER. NO PART OF THIS MANUAL, INCLUDING THE PRODUCTS AND SOFTWARE DESCRIBED IN IT MAY BE REPRODUCED, TRANSMITTED OR TRANSLATED INTO ANY LANGUAGE IN ANY FORM OR BY ANY MEANS WITHOUT WRITTEN PERMISSION OF THE MANUFACTURER.

THIS MANUAL CONTAINS ALL INFORMATION REQUIRED TO USE INTEL 945GSE CHIPSET MOTHER-BOARD SERIES AND WE DO ASSURE THIS MANUAL MEETS USER'S REQUIREMENT BUT WILL CHANGE, CORRECT ANY TIME WITHOUT NOTICE. MANUFACTURER PROVIDES THIS MANUAL "AS IS" WITHOUT WARRANTY OF ANY KIND, AND WILL NOT BE LIABLE FOR ANY INDIRECT, SPECIAL, INCIDENTAL OR CONSEQUENTIAL DAMAGES (INCLUDING DAMAGES FOR LOSS OF PROFIT, LOSS OF BUSINESS, LOSS OF USE OF DATA, INTERRUPTION OF BUSINESS AND THE LIKE).

PRODUCTS AND CORPORATE NAMES APPEARING IN THIS MANUAL MAY OR MAY NOT BE REGISTERED TRADEMARKS OR COPYRIGHTS OF THEIR RESPECTIVE COMPANIES, AND THEY ARE USED ONLY FOR IDENTIFICATION OR EXPLANATION AND TO THE OWNER'S BENEFIT, WITHOUT INTENT TO INFRINGE.

Manual Revision Information

Reversion	Revision History	Date
1.0	First Edition	July, 2009

Item Checklist

- Motherboard
- Cable(s)
- CD for motherboard utilities
- Motherboard User's Manual

Chapter 1

Introduction of the Motherboard

1-1 Feature of motherboard

- Intel 945GSE+ICH7M chipset.
- Onboard ATOM CPU, with low power consumption never denies high performance.
- Support FSB 533MHz.
- Support SODIMM DDRII 400/533 up to 2GB.
- Support CF card
- Support Mini-PCIE card
- Onboard REALTEK RTL 8111D Gigabit Ethernet LAN.
- Integrated ALC662 6-channel HD audio CODEC
- Support USB2.0 data transport demands.
- Support RS232/422/485 and watchdog.

1-2 Specification

Spec	Description
Design	● 3.5”SBC 6 layers; PCB size: 14.8x 10.2 cm
Chipset	● Intel 945GSE+ICH7M Chipset
Embedded CPU	● ATOM CPU
Memory Socket	● 200-pin DDRII SO-DIMM slot x1 ● Support DDRII 400/533MHz system Modules DDRII memory ● Expandable to 2GB.
Expansion Slots	● CF card slot x1 ● Mini-PCI E slot x1
Integrate IDE	● One PCI IDE controller that supports PCI Bus Mastering, ATA PIO/DMA and the ULTRA DMA /100/66 functions that deliver the data transfer rate up to 100MB/s.
LAN	● Integrated Realtek RTL8111D PCI-E Gigabit LAN. ● Support Fast Ethernet LAN function of providing 10Mb/100Mb/1000Mb Ethernet data transfer rate
Audio	● ALC662 6-channel HDAudio Codec integrated ● Audio driver and utility included
BIOS	● Award 8MB DIP Flash ROM
Multi I/O	● PS/2 keyboard ● DVI connector x1 ● RJ-45 gigabit LAN connector x2 ● USB2.0 port x 4(two from NF32-FPIO-LF) ● SATAII x1 ● Serial Port header x2 ● Front panel header x1 ● VGA header x1 ● Parallel header x1

	<ul style="list-style-type: none">● Audio connector x1 (from NF32-FPIO-LF)● RS422/485 connector x1● LVDS connector x1● GPIO connector x1● SYSTEM FAN connector x1
--	---

1-3 Layout Diagram

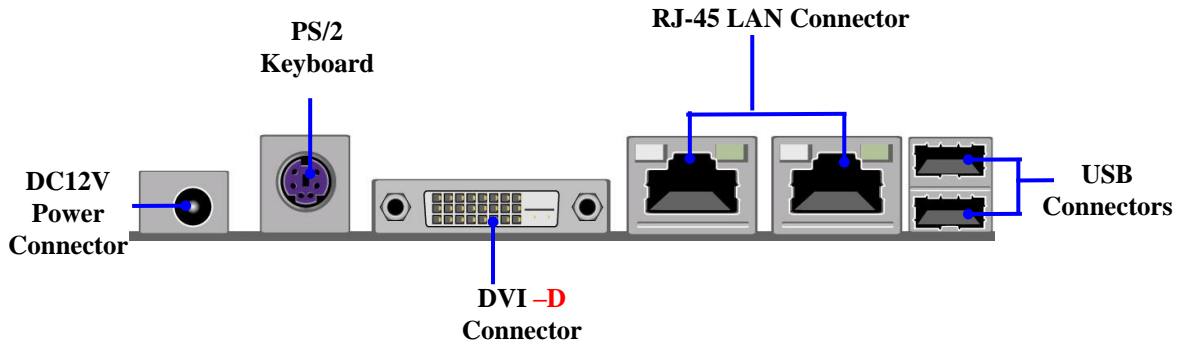

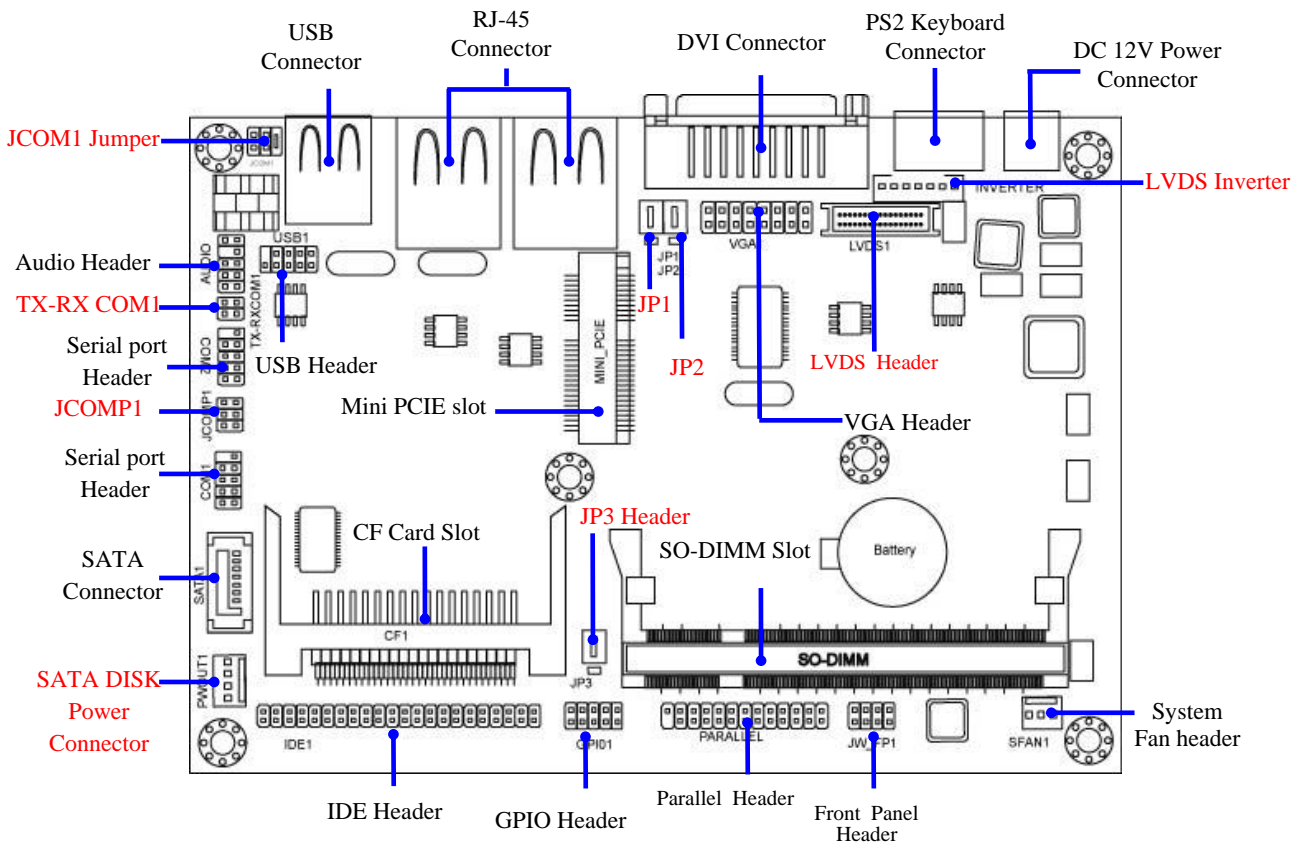

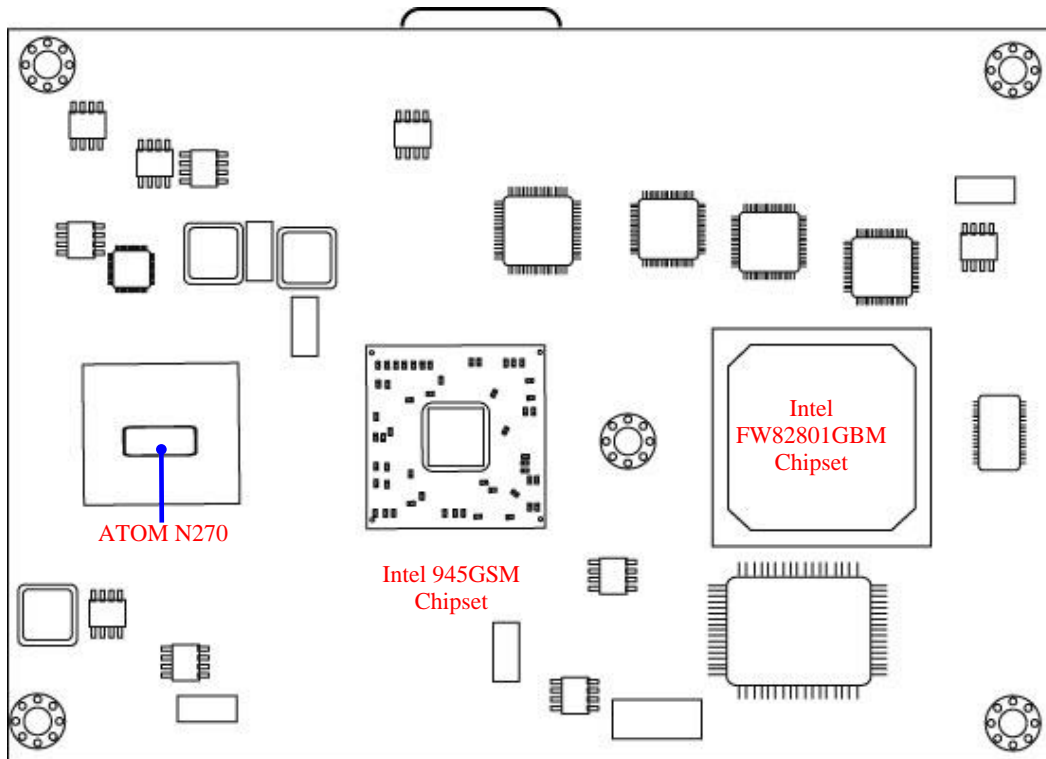

NF32-FPIO-LF Connectors and Headers

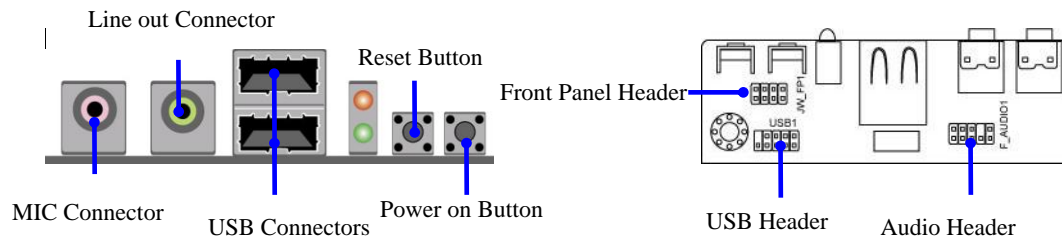

Jumper

Jumper	Name	Description
JCOM1	COM1 RS232/422/485 Function Select	6pin Block
JCOMP1	RS232 Power on Function Select	6pin Block
JP1	Inverter VCC 12V/5V Select	3-pin Block
JP2	LVDS5V/3.3V Select	3-pin Block
JP3	CF Card Master/Slave Mode Select	3-pin Block

Connectors

Connector	Name	Description
PWOUT1	Power out Connector	4-pin Connector
SATA1	Serial ATAII Connector	7-pin Connector
DC12V2	DC power Connector	DC Jack
PS1	PS2 Keyboard Connector	6-pin Female
DVI1	DVI port connector	24-pin Connector
LAN1/LAN2	RJ-45 LAN Connectors	8-pin Connectors
USB2	USB Port Connectors	4-pin Connectors
VGA1	VGA Port Connectors	15-pin Connectors
AUDIO1	AUDIO Connector	9-pin Connectors
USB1	USB Port Connectors	9-pin Connectors
SATA1	SATA Port Connectors	7-pin Connectors
PWOUT1	POWER Connectors	4-pin Connectors

Headers

Header	Name	Description
COM1,COM2	Serial port headers	9-pin block
TX-RXCOM1	Serial port headers	4-pin block
SFAN1	FAN Speed Headers	3-pin Block
USB1	USB header	9-pin block
IDE1	IDE Hard Disk Drive header	44-pin block
GPIO	GPIO header	10-pin block
LVDS1	LVDS Connector	30-pin Block

INVERTER1	LVDS Inverter Connector	7-pin Block
JW_FP1 (PWR LED/ HD LED/ /Power Button /Reset)	Front Panel Header (PWR LED/ HD LED/ /Power Button /Reset)	9-pin Block

Chapter 2

2-1 Jumper Setting

(1) JCOM1: COM1 Port RS232/422/485 function select

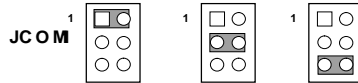
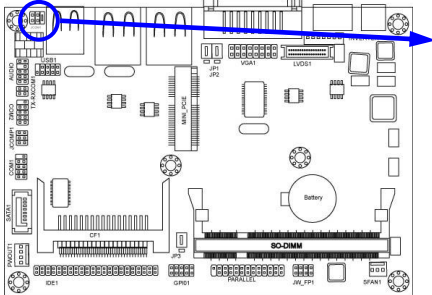

1-2 closed RS232; 3-4 closed RS485 5-6 closed RS422

(2) JCOMP1: COM1 Pin 9 function select

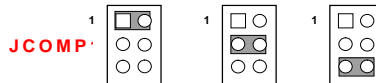
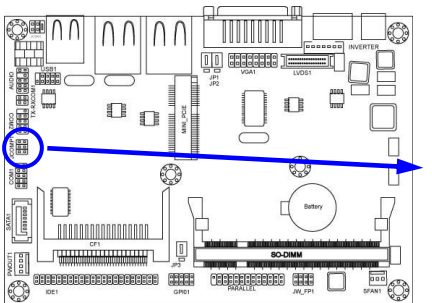

1-2 closed RS232; 3-4 closed +12V 5-6 closed +5V

(3) JP1: Inverter VCC 5V/12Vselect (3-pin)

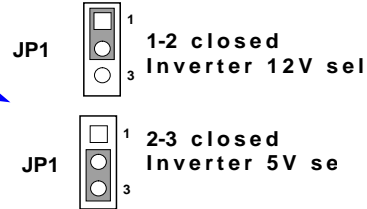
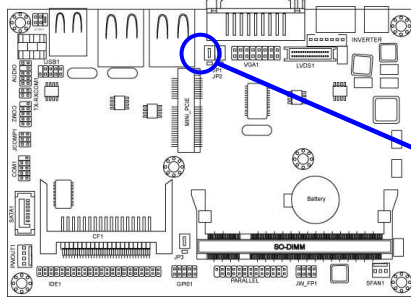

(4) JP2: LVDS 5V/3.3V Function setting (3-pin)

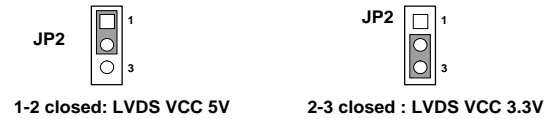
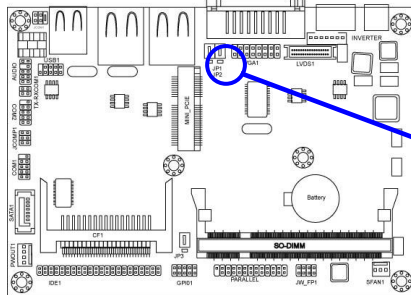

(4) JP3: CF card Master /Slave Mode setting (3-pin)

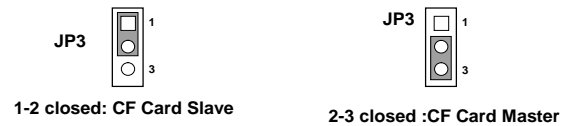
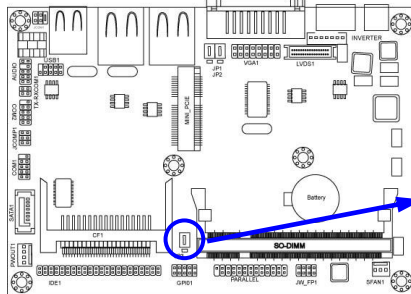

2-2-2 Headers

(1) Front panel audio (9-pin): AUDIO1

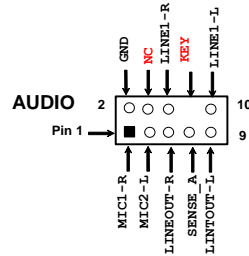
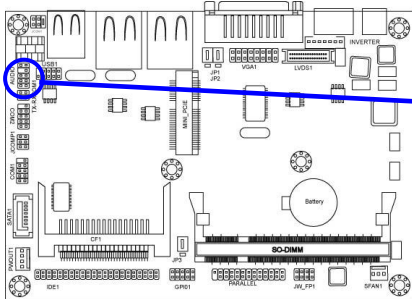

Line-Out, MIC Headers

(2) COM Connectors (9-pin): COM1/COM2

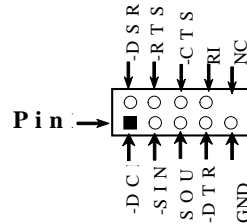
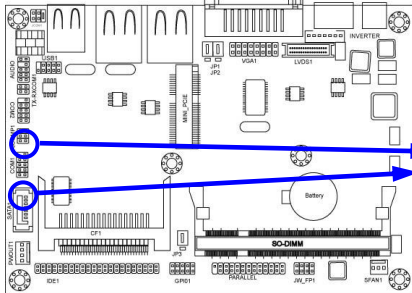

Serial Pin Block

(3)TX-RXCOM1 Header:

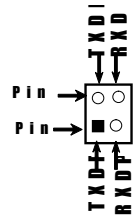
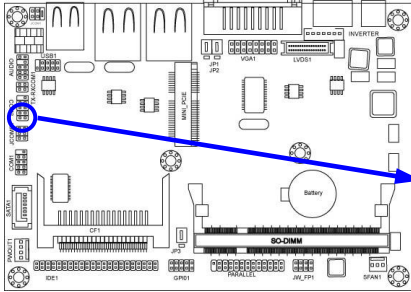

TX-RXCOM1 Hea

(4) JW-FP1 (9-pin)

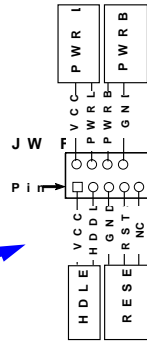
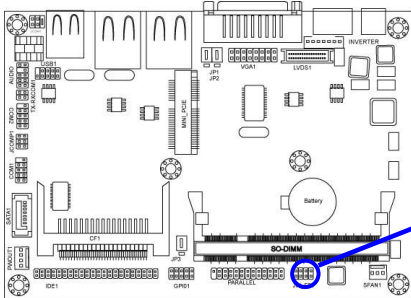

System Case Conn

(5) SFAN1 Headers (3-pin): SYSFAN1

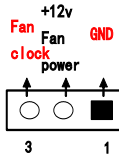
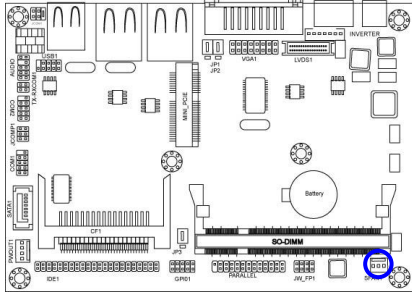

Fan Headers

(6) GPIO1 Connectors (10-pin): GPIO

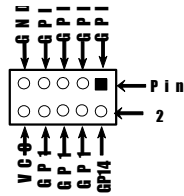
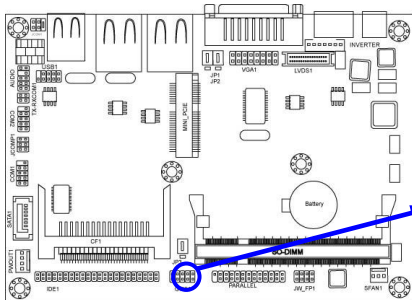

GPIO Connector

(7) LVDS1 Headers: LVDS

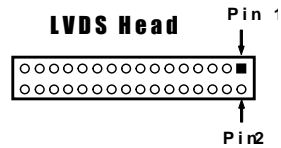
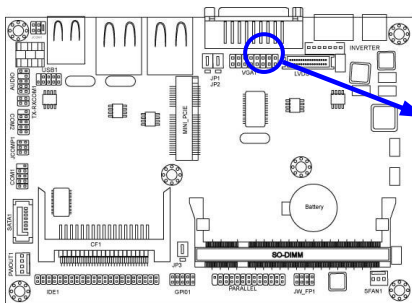

Pin NO.	Pin Define	Pin NO.	Pin Define
Pin 1	NC	Pin 2	NC
Pin 3	LVDS_CLKBN	Pin 4	LVDS_CLKBP
Pin 5	LVDSA_DATAN2	Pin 6	LVDSA_DATAP2
Pin 7	LVDSA_DATAN1	Pin 8	LVDSA_DATAP1
Pin 9	LVDSA_DATAN0	Pin 10	LVDSA_DATAP0
Pin 11	LVDS_DDC_DATA	Pin 12	LVDS_DDC_CLK
Pin 13	GND	Pin 14	GND
Pin 15	GND	Pin 16	GND
Pin 17	NC	Pin 18	NC
Pin 19	LVDS_CLKAP	Pin 20	LVDS_CLKAN
Pin 21	LVDSB_DATAP2	Pin 22	LVDSB_DATAN2
Pin 23	LVDSB_DATAP1	Pin 24	LVDSB_DATAN1
Pin 25	LVDSB_DATAP0	Pin 26	LVDSB_DATAN0
Pin 27	PVDD	Pin 28	PVDD
Pin 29	PVDD	Pin 30	PVDD

(8) Pin-headers of LVDS Inverter:

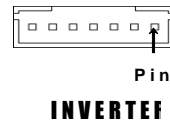
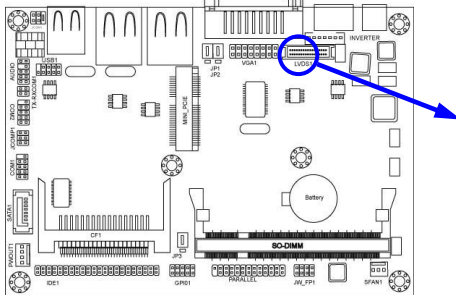

Pin NO.	Pin Define
---------	------------

Pin 1	VCC
Pin 2	VCC
Pin 3	GND
Pin 4	GND
Pin 5	Backlight
Pin 6	GND
Pin 7	Bright

Chapter 3

Introducing BIOS

Notice! The BIOS options in this manual are for reference only. Different configurations may lead to difference in BIOS screen and BIOS screens in manuals are usually the first BIOS version when the board is released and may be different from your purchased motherboard. Users are welcome to download the latest BIOS version form our official website.

The BIOS is a program located on a Flash Memory on the motherboard. This program is a bridge between motherboard and operating system. When you start the computer, the BIOS program will gain control. The BIOS first operates an auto-diagnostic test called POST (power on self test) for all the necessary hardware, it detects the entire hardware device and configures the parameters of the hardware synchronization. Only when these tasks are completed done it gives up control of the computer to operating system (OS). Since the BIOS is the only channel for hardware and software to communicate, it is the key factor for system stability, and in ensuring that your system performance as its best.

In the BIOS Setup main menu of Figure 3-1, you can see several options. We will explain these options step by step in the following pages of this chapter, but let us first see a short description of the function keys you may use here:

- Press <Esc> to quit the BIOS Setup.
- Press ↑↓←→ (up, down, left, right) to choose, in the main menu, the option you want to confirm or to modify.
- Press <F10> when you have completed the setup of BIOS parameters to save these parameters and to exit the BIOS Setup menu.

-
-
- Press Page Up/Page Down or +/- keys when you want to modify the BIOS parameters for the active option.

3-1 Entering Setup

Power on the computer and by pressing immediately allows you to enter Setup.

If the message disappears before your respond and you still wish to enter Setup, restart the system to try again by turning it OFF then ON or pressing the “RESET” button on the system case. You may also restart by simultaneously pressing <Ctrl>, <Alt> and <Delete> keys. If you do not press the keys at the correct time and the system does not boot, an error message will be displayed and you will again be asked to

Press to enter Setup

3-2 Getting Help

Main Menu

The on-line description of the highlighted setup function is displayed at the bottom of the screen.

Status Page Setup Menu/Option Page Setup Menu

Press F1 to pop up a small help window that describes the appropriate keys to use and the possible selections for the highlighted item. To exit the Help Window, press <Esc>.

3-3 The Main Menu

Once you enter Award® BIOS CMOS Setup Utility, the Main Menu (Figure 3-1) will appear on the screen. The Main Menu allows you to select from fourteen setup functions and two exit choices. Use arrow keys to select among the items and press <Enter> to accept or enter the sub-menu.

Phoenix - AwardBIOS CMOS Setup Utility

➤ Standard CMOS Features	➤ Miscellaneous Control
➤ Advanced BIOS Features	Load Optimized Defaults
➤ Advanced Chipset Features	Load standard Defaults
➤ Integrated Peripherals	Set Supervisor Password
➤ Power Management Setup	Set User Password
➤ PnP/PCI Configurations	Save & Exit Setup
➤ PC Health Status	Exit Without Saving
Esc : Quit	↑↓→← : Select Item
F10 : Save & Exit Setup	

Figure 3-1

Standard CMOS Features

Use this Menu for basic system configurations.

Advanced BIOS Features

Use this menu to set the Advanced Features available on your system.

Advanced Chipset Features

Use this menu to change the values in the chipset registers and optimize your system's performance.

Integrated Peripherals

Use this menu to specify your settings for integrated peripherals.

Power Management Setup

Use this menu to specify your settings for power management.

PnP/PCI Configuration

Use this menu to specify your settings for PnP and PCI configurations.

PC Health Status

This entry shows your PC health status.

Miscellaneous Control

Use this menu to specify your settings for Miscellaneous Control.

Load Optimized Defaults

Use this menu to load the BIOS default values these are setting for optimal performances system operations for performance use.

Load Standard Defaults

Use this menu to load the BIOS default values for the minimal/stable performance system operation

Set Supervisor Password

Use this menu to set supervisor password.

Set User Password

Use this menu to set user password.

Save & Exit Setup

Save CMOS value changes to CMOS and exit setup.

Exit Without Saving

Abandon all CMOS value changes and exit setup.

3-4 Standard CMOS Features

The items in Standard CMOS Setup Menu are divided into several categories. Each category includes no, one or more than one setup items. Use the arrow keys to highlight the item and then use the <PgUp> or <PgDn> keys to select the value you want in each item.

Phoenix - AwardBIOS CMOS Setup Utility
Standard CMOS Features

Date (mm:dd:yy)	Wed, Jun18, 2009	Item Help
Time (hh:mm:ss)	16 : 48 : 35	
> SATA Port1 Master	WDC WD800BEVS-22RST0	
> IDE Channel1 Master	None	
> IDE Channel1 Slave	None	Menu Level >
Video	EGA/VGA	
Halt On	All Errors	
Base Memory	639k	
Extended Memory	1039360k	
Total Memory	1040384k	

↑↓←→ Move Enter:Select +/-/PU/PD:Value F10:Save ESC:Exit F1:General Help F5:Previous Values F6:Optimized Defaults F7:Standard Defaults

Date

The date format is <day><month><date><year>.

Day Day of the week is from Sun to Sat, determined by BIOS. Read-only.

Month The month is from Jan. through Dec.

Date The date from 1 to 31 can be keyed by numeric function keys.

Year The year depends on the year of the BIOS.

Time

The time format is <hour><minute><second>.

SATA Port Master/IDE Channel 1 Master/Slave

Press Enter to enter the subitem and then press PgUp/<+> or PgDn/<-> to select None, Auto type. Note that the specifications of your drive must match with the drive table. If the controller of HDD interface is SCSI, the selection shall be “None”.

If the controller of HDD interface is CD-ROM, the selection shall be “None”

Access Mode The settings are CHS, LBA, Large and Auto.

Capacity The capacity of the hard disk driver.

Cylinder number of cylinders

Head number of heads

Precomp write precomp

Landing Zone landing zone

Sector number of sectors

Video

The optional settings are: EGA/VGA; CGA40; CGA80; Mono.

Halt On

Three optional settings are: All Errors; No Errors; All, But Keyboard.

3-5 Advanced BIOS Features

Phoenix - AwardBIOS CMOS Setup Utility

Advanced BIOS Features

Virus Warning	Disabled	Item Help
➤ CPU Feature	Press Enter	
➤ Hard Disk Boot Priority	Press Enter	Menu Level >
Hyper-Threading Technology	Enabled	
Quick power on self Test	Enabled	
First Boot Device	HARD DISK	
Second Boot Device	CDROM	
Third Boot Device	Disabled	
Boot other Device	Enabled	
Boot Up NumLock Status	On	
Typematic Rate Setting	Disabled	
X Typematic Rate (Chars/Sec)	6	
X Typematic Delay (Msec)	250	
Security Option	Setup	
X APIC Mode	Enabled	
MPS Version Control For OS	1.4	
OS Select For DRAM > 64MB	Non-OS2	
HDD S.M.A.R.T. Capability	Disabled	
↑↓← Move Enter:Select +/-/PU/PD:Value F10:Save ESC:Exit F1:General Help F5:Previous Values F6:Optimized Defaults F7:Standard Defaults		

Virus Warning

The selection Allow you to choose the VIRUS Warning feature for IDE Hard Disk boot sector protection. If this function is enabled and someone attempt to write data into this area, BIOS will show a warning message on screen and alarm beep.

Disabled (default) No warning message to appear when anything attempts to access the boot sector or hard disk partition table.

Enabled Activates automatically when the system boots up causing a warning message to appear when anything attempts to access the boot sector of hard disk partition table.

Hard Disk Boot Priority

The selection is for you to choose the hard disk drives priorities to boot from.

Quick Power On Self-Test

This category speeds up Power On Self Test (POST) after you power on the computer. If this is set to Enabled, BIOS will shorten or skip some check items during POST.

- Enabled** (default) Enable quick POST
- Disabled** Normal POST

First/Second/Third Boot Device

The BIOS attempts to load the operating system from the devices in the sequence selected in these items. The optional settings are LS120, Hard disk, CDROM, ZIP100, USB-FDD, USB-ZIP, USB-CDROM, Legacy LAN and Disabled.

Boot Up NumLock Status

The default value is On.

- On** (default) Keypad is numeric keys.
- Off** Keypad is arrow keys.

Typematic Rate Setting

Keystrokes repeat at a rate determined by the keyboard controller. When enabled, the typematic rate and typematic delay can be selected. The settings are: Enabled/Disabled.

Typematic Rate (Chars/Sec)

Sets the number of times a second to repeat a keystroke when you hold the key down. The settings are: 6, 8, 10, 12, 15, 20, 24, and 30.

Typematic Delay (Msec)

Sets the delay time after the key is held down before beginning to repeat the keystroke. The settings are 250, 500, 750, and 1000.

Security Option

This category allows you to limit access to the system and Setup, or just to Setup.

- System** The system will not boot and access to Setup will be denied if the correct password is not entered at the prompt.
- Setup** (default) The system will boot, but access to Setup will be denied if the correct password is not entered prompt.

MPS Version Control for OS 1.4

This option is only valid for multiprocessor motherboards as it specifies the version of the Multiprocessor Specification (MPS) that the motherboard will use.

OS Select for DRAM > 64MB

Allows OS2® to be used with >64MB or DRAM. Settings are Non-OS/2 (default) and OS2. Set to OS/2 if using more than 64MB and running OS/2®.

HDD S.M.A.R.T Capability

This option allow you to enable the HDD S.M.A.R.T Capability (Self-Monitoring, Analysis and Reporting Technology) . You can choose from Enabled and Disabled.

3-5-1 CPU Features

Phoenix - AwardBIOS CMOS Setup Utility

CPU Feature

Limit CPU ID MaxVol	Disabled	Item Help
CPU C State Capability	Disabled	
Enhanced Intel Speedstep Tech	Enabled	Menu Level >
↑↓→← Move Enter:Select +/-/PU/PD:Value F10:Save ESC:Exit F1:General Help F5:Previous Values F6:Optimized Defaults F7:Standard Defaults		

Limit CPUID Maxval

This option support the max ID of comparatively old processor.

CPU C State Compatibility

The optional settings are: Disabled; C2; C4.

Enhanced Intel Speedstep Tech

This option can provide average power savings depending on system usage and design.

3-6 Advanced Chipset Features

The Advanced Chipset Features Setup option is used to change the values of the chipset registers. These registers control most of the system options in the computer.

Phoenix - AwardBIOS CMOS Setup Utility

Advanced Chipset Features

DRAM Timing Settings	Press Enter	Item Help	
X SDRAM CAS Latency Time	Auto	Menu Level >	
X SDRAM Cycle Time	Auto		
X SDRAM RAS-to-CAS Delay	Auto		
X SDRAM RAS Precharge Time	Auto		
System BIOS Cacheable	Disabled		
Video BIOS Cacheable	Disabled		
Memory Hole at 15M-16M	Disabled		
*** VGA Setting ***			
Onchip Frame Buffer Size	8MB		
DVMT Mode	DVMT		
DVMT/FIXED Memory Size	128 MB		
Boot Display	Auto		
LVDS Support	Disabled		
Panel Number	800x600		
↑↓→← Move Enter:Select +/-/PU/PD:Value F10:Save ESC:Exit F1:General Help F5:Previous Values F6:Optimized Defaults F7:Standard Defaults			

DRAM Timing Selectable

The optional settings are: By SPD; Manual. If you chose Manual, you could activate the four items following it and make modification manually.

System BIOS Cacheable

Selecting Enabled allows caching of the system BIOS ROM at F0000h-FFFFFFh, resulting in better system performance. However, if any program writes to this memory area, a system error may result. The settings are: Enabled and Disabled.

OnChip Frame Buffer Size

The optional settings are: 1MB; 8MB.

DVMT Mode

The optional settings are:FIXED; DVMI; BOTH.

DVMT/FIXED Memory Size

The optional settings are: 64 MB; 128MB; 224MB.

Boot Display

The optional settings are: Auto; CRT; DVI; LCD; CRT+LCD;CRT+DVI.

3-7 Integrated Peripherals

Phoenix - AwardBIOS CMOS Setup Utility

Integrated peripherals

➤ Onboard IDE Function	Press Enter	Item Help
➤ Onboard Device Function	Press Enter	
➤ Onboard SuperIO Function	Press Enter	Menu Level >>
PWR Status after PWR Failure	Always Off	
Init Display First	PCI Slot	
↑↓→← Move Enter:Select +/-/PU/PD:Value F10:Save ESC:Exit F1:General Help F5:Previous Values F6:Optimized Defaults F7:Standard Defaults		

PWR Status after PWR Failure

The optional settings are: Former Status; Always On; Always Off.

Init Display First

The optional settings are: PCI slot; On-chip VGA.

3-7-1 Onboard IDE Function

Phoenix - AwardBIOS CMOS Setup Utility

Onboard IDE Function

On-Chip IDE Channel	Enabled	Item Help
IDE Channel Master PIO	Auto	
IDE Channel Slave PIO	Auto	Menu Level >>
IDE Channel Master UDMA	Auto	
IDE Channel Slave UDMA	Auto	
IDE DMA Transfer Access	Enabled	
IDE HDD Block Mode	Enabled	
Delay for HDD (Secs)	6	
SATA Port Speed Settings	Disabled	

↑↓←→ Move Enter:Select +/-/PU/PD:Value F10:Save ESC:Exit F1:General Help F5:Previous Values F6:Optimized Defaults F7:Standard Defaults

IDE Master/Slave PIO

The two IDE PIO (Programmed Input/Output) fields let you set a PIO mode (0-4) for each of the two IDE devices that the onboard IDE interface supports. Modes 0 through 4 provide successively increased performance. In Auto mode, the system automatically determines the best mode for each device. The settings are: Auto, Mode 0, Mode 1, Mode 2, Mode 3, Mode 4.

IDE Master/Slave UDMA

Ultra DMA/33 implementation is possible only if your IDE hard drive supports it and the operating environment includes a DMA driver (Windows 95 OSR2 or a third-party IDE bus master driver). If your hard drive and your system software both support Ultra DMA133, select Auto to enable BIOS support. The settings are: Auto, Disabled.

IDE DMA Transfer Access

The integrated peripheral controller contains an IDE interface with support for one IDE channels. Select Enabled to activate each channel separately. The settings are: Enabled and Disabled.

IDE HDD Block Mode

Block mode is also called block transfer, multiple commands, or multiple sector read/write. If your IDE hard drive supports block mode (most new drives do), select Enabled for automatic detection of the optimal number of block read/writes per sector the drive can support. The settings are: Enabled, Disabled.

Delay for HDD (Sec.)

The optional settings range from 0 to 15 seconds.

SATA Port Speed Settings

The optional settings are: Disabled; Force GENI; Force GEN II.

3-7-2 Onboard Device Function

Phoenix - AwardBIOS CMOS Setup Utility

Onboard Device Function

Onboard PCIE Lan1 Controller	Enabled	Item Help
Onboard PCIE Lan2 Controller	Enabled	
Onboard PCIE Lan1 BootROM	Disabled	Menu Level >>
Onboard PCIE Lan2 BootROM	Disabled	
High Definition Audio	Enabled	
USB HOST Controller	Enabled	
USB 2.0 Function	Enabled	
USB Keyboard Legacy Support	Enabled	
USB Mouse Legacy Support	Enabled	
USB Storage Legacy Support	Enabled	
USB Mass Storage Device Boot Settingg		
↑↓→← Move Enter:Select +/-/PU/PD:Value F10:Save ESC:Exit F1:General Help F5:Previous Values F6:Optimized Defaults F7:Standard Defaults		

High Definition Audio

This item allows you to decide to enable/disable the chipset family to support HD Audio. The settings are: Enabled, Disabled.

Onboard PCIE LAN1/LAN2 Bootrom

Decide whether to invoke the boot ROM of the onboard LAN chip. The optional settings are IDE; RAID.

USB 2.0 Function /Keyboard/Mouse /Storage Support

Select *Enabled* if your system contains a Universal Serial Bus (USB) controller and you have a USB mouse /keyboard/USB storage device. The settings are: Enabled, Disabled.

3-7-3 Onboard SuperIO Function

Phoenix - AwardBIOS CMOS Setup Utility

Onboard Device Function

Onboard Serial Port1	3F8/IRQ4	Item Help Menu Level >>
Onboard Serial Port1 Mode	RS232	
Onboard Serial Port2	2F8/IRQ3	
UART2 Mode Select	Normal	
X IR Duplex Mode	Half	
Onboard Parallel Port	378/IRQ7	
Parallel Port Mode	SPP	
X ECP Mode Use DMA	3	
Watch Dog Timer Select	Disabled	
X WatchDog Timer Value	255	
X WatchDog Timer Unit	Sec	
↑↓→← Move Enter:Select +/-/PU/PD:Value F10:Save ESC:Exit F1:General Help F5:Previous Values F6:Optimized Defaults F7:Standard Defaults		

Onboard Serial Port 1/2

The optional settings are: Disabled, 3F8/IRQ4, 2F8/IRQ3, 3E8/IRQ4, 2E8/IRQ3.

Onboard Serial Port1 Mode

The optional settings are: RS232; RS422 and RS485.

UART2 Mode Select

This item allows you to determine which InfraRed(IR) function of the onboard I/O chip. The optional settings are Normal and IrDA.

Onboard Parallel Port

The optional settings are: Disabled, 378/IRQ7, 278/IRQ5 and 3BC/IRQ7.

Parallel Port Mode

- SPP : Standard Parallel Port
- ECP : Enhanced Com Port
- EPP : Enhanced Parallel Port

ECP +EPP

To operate the onboard parallel port as Standard Parallel Port only, choose “SPP.” To operate the onboard parallel port in the EPP modes simultaneously, choose “EPP.” By choosing “ECP”, the onboard parallel port will operate in ECP mode only. Choosing “ECP+EPP” will allow the onboard parallel port to support both the ECP and EPP modes simultaneously. The ECP mode has to use the DMA channel, so choose the onboard parallel port with the ECP feature. After selecting it, the following message will appear: “ECP Mode Use DMA” at this time, the user can choose between DMA channels 3 to 1.

Watchdog Timer Select

This item is used to activate the watchdog function. The optional settings are: Enabled; Disabled. When set it as Enabled user can choose configuration figures in subitems.

Watchdog Timer Value

This item is only activated when Watchdog Timer Select is set as Enabled and users can set a value from the range of 0~255

Watchdog Timer Unit

This item is only activated when Watchdog Timer Select is set as Enabled and the optional units are: Sec. and Min.

*Note: User needs an additional Watchdog Programming Reference Code to make use of this BIOS function. Detailed procedures please download from our website if necessary.

3-8 Power Management Setup

The Power Management Setup allows you to configure your system to most effectively save energy saving while operating in a manner consistent with your own style of computer use.

Phoenix - AwardBIOS CMOS Setup Utility

Power Management Setup

ACPI Function	Enabled	Item Help
ACPI Suspend Type	S1(POS)	
Power Management	User Define	Menu Level >
Video off Method	V/H SYNC+Blank	
Video off in Suspend	Yes	
Suspend Type	Stop Grant	
MODEN USE IRQ	3	
Suspend Mode	Disabled	
Soft-off by PWR-BTTN	Instant-off	
Power on by ring	Disabled	
Wake-Up by USB KB from S3(S4)	Disabled	
PS2 KB/MS Wake-up from S3-S5	Disabled	
Resume by Alarm	Disabled	
X Date (of Month) Alarm	0	
X Time (hh:mm:ss)Alarm	0:0:0	
> PM Timer Reload Events	Press Enter	
> PCI Express PM Function	Press Enter	
↑↓←→ Move Enter:Select +/-/PU/PD:Value F10:Save ESC:Exit F1:General Help F5:Previous Values F6:Optimized Defaults F7:Standard Defaults		

ACPI Function

This item allows you to Enabled/Disabled the Advanced Configuration and Power Management (ACPI). The settings are Enabled and Disabled.

ACPI Suspend Type

Use this item to select ACPI suspend type. The optional settings are: S1(POS); S3 (STR).

Power Management

The optional settings are: User Define; Min Saving; Max Saving.

Video Off Method

This determines the manner in which the monitor is blanked.

DPMS (default) Initial display power management signaling.

Blank Screen This option only writes blanks to the video buffer.

V/H SYNC+Blank This selection will cause the system to turn off the vertical and horizontal synchronization ports and write blanks to the video buffer.

MODEM Use IRQ

If you want an incoming call on a modem to automatically resume the system from a power-saving mode, use this item to specify the interrupt request line (IRQ) that is used by the modem. You might have to connect the fax/modem to the motherboard Wake On Modem connector for this feature to work.

Soft-Off by PWRBTN

Under ACPI (Advanced Configuration and Power management Interface) you can create a software power down. In a software power down, the system can be resumed by Wake up Alarms. This item lets you install a software power down that is controlled by the power Button on your system. If the item is set to Instant-Off, then the power button causes a software power down. If the item is set to Delay 4 Sec, then you have to hold the power button down for four seconds to cause a software power down.

Wake Up Events

Users can press Enter to select the relative items for wake up events. Set it as Disabled or Enabled in Wake-Up by USB KB from S3(S4); PS2 KB/MS Wake-Up from S3-S5

Resume by Alarm

When set to Enabled, additional fields become available and you can set the date (day of the month), hour, minute and second to turn on your system. When set to 0 (zero) for the day of the month, the alarm will power on your system every day at the specified time .

Date (of month)

You can choose which month the system will boot up. Set to 0, to boot every day. The optional settings range from 0 to 31

Time (hh:mm:ss)

You can choose what hour, minute and second the system will boot up.

Note: If you have change the setting, you must let the system boot up until it goes to the operating system, before this function will work.

3-9 PnP/PCI Configuration

Phoenix - AwardBIOS CMOS Setup Utility

Pnp/PCI Configuration

➤ IRQ Resources	Press Enter	Item Help
PCI/VGA Palette Snoop	Disabled	
PCIExpress Relative Items		Menu Level >
Maximum Payload Size	128	
↑↓→← Move Enter:Select +/-/PU/PD:Value F10:Save ESC:Exit F1:General Help F5:Previous Values F6:Optimized Defaults F7:Standard Defaults		

PCI/VGA Palette Snoop

This item is designed to overcome problems that can be caused by some non-standard VGA cards. This board includes a built-in VGA system that does not require palette snooping so you must leave this item disabled.

IRQ Resources

Names the interrupt request (IRQ) line assigned to the USB on your system. Activity of the selected IRQ always awakens the system.

3-10 PC Health Status

This section shows the Status of you CPU, Fan, and Warning for overall system status. This is only available if there is Hardware Monitor onboard.

Phoenix - AwardBIOS CMOS Setup Utility

PC Health Status

Shutdown Temperature	Disabled	Item Help
CPU Thermal-Throttling	Disabled	
X CPU Thermal-Throttling Temp	70c	Menu Level >
X CPU Thermal-Throttling Duty	50%	
X CPU Thermal-Throttling Beep	Enabled	
Show PC Health In Post	Enabled	
> Smart fan configurations	Press Enter	
VCC3V	3.34V	
Vcore	1.20V	
NB	1.04V	
+5V	5.00V	
+12V	12.32V	
5VSB	5.00V	
VDIMM	1.80V	
VSB3V	3.36V	
Vbat	3.31V	
CPU Temperature	40C/104F	
SYS Temperature	39C/102F	
SYSFAN1 Speed	0RPM	
↑↓→← Move Enter:Select +/-/PU/PD:Value F10:Save ESC:Exit F1:General Help F5:Previous Values F6:Optimized Defaults F7:Standard Defaults		

Shutdown Temperature

This item can let users setting the Shutdown temperature, when CPU temperature over this setting the system will auto shutdown to protect CPU.

Show PC Health in Post

During Enabled, it displays information list below. The choice is either Enabled or Disabled

CPU Thermal Throttling

The optional settings are: Disabled; Enabled. When it is set as Enabled user could set value for CPU Thermal-Throttling Temp.; CPU Thermal-Throttling Duty and CPU Thermal-Throttling Beep.

Smart Fan Configuration

The optional settings are: Disabled; Enabled. When it is set as Enabled user could set value

for SYS FAN1 Full-Speed Temp., SYS FAN1 Idle Temp. and SYS FAN1 IDLE-Speed Duty.
**VCC3V/Vcore/ /NB/+5V/+12V/5 VSB/VDIMM/VSB3V/Vbat/ CPU Temperature/
 System Temperature/ SYSFAN1 Speed/**
 This will show the CPU/FAN/System voltage chart and FAN Speed.

3-11 Miscellaneous Control

Phoenix – AwardBIOS CMOS Setup Utility

Miscellaneous Control

CPU Clock Ratio Unlock	Enabled	Item Help
CPU Clock Ratio	12X	
Spread Spectrum	Disabled	Menu Level >
*** Current Host/PCIClock is 133/33 MHz***		
Host/PCI Clock at Next Boot	133/33MHz	
Current DRAM Clock is 533MHz		
DRAM Clock at Next Boot is	SPD (DDR 533)	
↑↓← Move Enter:Select +/-/PU/PD:Value F10:Save ESC:Exit F1:General Help F5:Previous Values F6:Optimized Defaults F7:Standard Defaults		

CPU Clock Ratio Unlock

This item is used to lock or unlock CPU ratio.

CPU Clock Ratio

The optional settings range from 6X to 12X.

DRAM Clock at Next Boot

This item allows you to set DRAM clock. The optional settings are: DDR400; DDR533; and SPD.

3-12 Password Setting

You can set either supervisor or user password, or both of them. The differences are:

Supervisor password: Can enter and change the options of the setup menus.

User password: Can only enter but do not have the right to change the options of the setup menus. When you select this function, the following message will appear at the center of the screen to assist you in creating a password.

ENTER PASSWORD:

Type the password, up to eight characters in length, and press <Enter>. The password typed now will clear any previously entered password from CMOS memory. You will be asked to confirm the password. Type the password again and press <Enter>. You may also press <Esc> to abort the selection and not enter a password.

To disable a password, just press <Enter> when you are prompted to enter the password. A message will confirm that the password will be disabled. Once the password is disabled, the system will boot and you can enter Setup freely.

PASSWORD DISABLED.

When a password has been enabled, you will be prompted to enter it every time you try to enter Setup. This prevents an unauthorized person from changing any part of your system configuration.

Additionally, when a password is enabled, you can also require the BIOS to request a password every time your system is rebooted. This would prevent unauthorized use of your computer.

You determine when the password is required within the BIOS Features Setup Menu and its Security option. If the Security option is set to “System”, the password will be required both at boot and at entry to Setup. If set to “Setup”, prompting only occurs when trying to enter Setup.

3-13 Load Standard/Optimized Defaults

Load Standard Defaults

When you press <Enter> on this item, you get confirmation dialog box with a message similar to:

Load Standard Defaults (Y/N)? N

Pressing <Y> loads the BIOS default values for the most stable, minimal-performance system operations.

Load Optimized Defaults

When you press <Enter> on this item, you get a confirmation dialog box with a message similar to:

Load Optimized Defaults (Y/N)? N

Pressing <Y> loads the default values that are factory settings for optimal performance system operations.