

TECHNICAL MANUAL
Of
VIA VX800
Based
Mini-ITX M/B For VIA C7/Eden/Nano
Processor

NO.G03-NF77-F

Rev.2.0

Release date: December, 2008

Trademark:

* Specifications and Information contained in this documentation are furnished for information use only, and are subject to change at any time without notice, and should not be construed as a commitment by manufacturer.

Environmental Protection Announcement

Do not dispose this electronic device into the trash while discarding. To minimize pollution and ensure environment protection of mother earth, please recycle.



TABLE OF CONTENT

| | |
|--|----|
| USER'S NOTICE | iv |
| MANUAL REVISION INFORMATION | iv |
| ITEM CHECKLIST | iv |
| CHAPTER 1 INTRODUCTION OF MOTHERBOARD | |
| 1-1 FEATURE OF MOTHERBOARD | 1 |
| 1-2 SPECIFICATION..... | 2 |
| 1-3 LAYOUT DIAGRAM & JUMPER SETTING | 3 |
| CHAPTER 2 HARDWARE INSTALLATION | |
| 2-1 JUMPER SETTING | 7 |
| 2-2 CONNECTORS AND HEADERS | 10 |
| 2-2-1 CONNECTORS..... | 10 |
| 2-2-2 HEADERS | 10 |
| CHAPTER 3 INTRODUCING BIOS | |
| 3-1 ENTERING SETUP | 16 |
| 3-2 GETTING HELP | 16 |
| 3-3 THE MAIN MENU..... | 16 |
| 3-4 STANDARD BIOS FEATURES..... | 18 |
| 3-5 ADVANCED BIOS FEATURES..... | 20 |
| 3-5-1 CPU FEATURE..... | 23 |
| 3-6 ADVANCED CHIPSET FEATURES..... | 23 |
| 3-6-1 DRAM TIMING SETTINGS | 24 |
| 3-6-2 VGA TIMING SETTINGS..... | 25 |
| 3-6-3 PCI TIMING SETTINGS..... | 25 |
| 3-7 INTEGRATED PERIPHERALS | 26 |
| 3-7-1 ONBOARD IDE FUNCTION..... | 26 |
| 3-7-2 ONBOARD DEVICE FUNCTIONS..... | 27 |
| 3-7-3 ONBOARD SUPERIO FUNCTIONS..... | 28 |
| 3-7-4 USB DEVICE SETTINGS..... | 30 |
| 3-8 POWER MANAGERMENT SETUP..... | 31 |
| 3-9 PNP/PCI CONFIGURATION | 32 |
| 3-10 PC HEALTH STATUS..... | 33 |
| 3-11 MISCELLANEOUS CONTROL | 34 |

| | | |
|------|--|----|
| 3-12 | PASSWORD SETTING | 35 |
| 3-13 | LOAD STANDARD/OPTIMIZED DEFAULTS | 36 |

USER'S NOTICE

COPYRIGHT OF THIS MANUAL BELONGS TO THE MANUFACTURER. NO PART OF THIS MANUAL, INCLUDING THE PRODUCTS AND SOFTWARE DESCRIBED IN IT MAY BE REPRODUCED, TRANSMITTED OR TRANSLATED INTO ANY LANGUAGE IN ANY FORM OR BY ANY MEANS WITHOUT WRITTEN PERMISSION OF THE MANUFACTURER.

THIS MANUAL CONTAINS ALL INFORMATION REQUIRED TO USE VIA VX800 CHIPSET MOTHER-BOARD SERIES AND WE DO ASSURE THIS MANUAL MEETS USER'S REQUIREMENT BUT WILL CHANGE, CORRECT ANY TIME WITHOUT NOTICE. MANUFACTURER PROVIDES THIS MANUAL "AS IS" WITHOUT WARRANTY OF ANY KIND, AND WILL NOT BE LIABLE FOR ANY INDIRECT, SPECIAL, INCIDENTAL OR CONSEQUENTIAL DAMAGES (INCLUDING DAMAGES FOR LOSS OF PROFIT, LOSS OF BUSINESS, LOSS OF USE OF DATA, INTERRUPTION OF BUSINESS AND THE LIKE).

PRODUCTS AND CORPORATE NAMES APPEARING IN THIS MANUAL MAY OR MAY NOT BE REGISTERED TRADEMARKS OR COPYRIGHTS OF THEIR RESPECTIVE COMPANIES, AND THEY ARE USED ONLY FOR IDENTIFICATION OR EXPLANATION AND TO THE OWNER'S BENEFIT, WITHOUT INTENT TO INFRINGE.

Manual Revision Information

| Reversion | Revision History | Date |
|-----------|------------------|----------------|
| 2.0 | Second Edition | December, 2008 |

Item Checklist

- Motherboard
- Cable(s)
- CD for motherboard utilities
- Motherboard User's Manual
- I/O Back panel Shield

Chapter 1

Introduction of the Motherboard

1-1 Feature of motherboard

- * VIA VX800 chipset.
- * Onboard optional C7/Eden/Nano CPU, with low power consumption and never denies high performance.
- * Support optional FSB 400/533 /800MHz.
- * Support DDRII 400/533/667 up to 2GB.
- * Onboard REALTEK RTL 8111C Gigabit Ethernet LAN.
- * Integrated VIA 1708 B 6-channel HD audio CODEC
- * Support USB2.0 data transport demands.

1-2 Specification

| Spec | Description |
|------------------------|---|
| Design | * Mini ITX form factor 4 layers PCB size: 17.0x17.0cm |
| Chipset | * VIA VX800 Chipset |
| Embedded CPU | * Optional VIA C7 /Eden/Nano seriesCPU |
| Memory Socket | * 240-pin DDRII DIMM socket x1 * Support DDRII 400/533/667MHz system Modules DDR memory * Expandable to 2GB. |
| Expansion Slots | * 32-bit PCI slot x 1pcs |
| Integrate IDE | * One PCI IDE controller that supports PCI Bus Mastering, ATA PIO/DMA and the ULTRA DMA 133/100/66 functions that deliver the data transfer rate up to 133 MB/s; |
| LAN | * Integrated Realtek RTL8111C PCI-E LAN chip. * Support Fast Ethernet LAN function of providing 10Mb/100Mb/1000Mb Ethernet data transfer rate |
| Audio | * VIA 1708B 6-channel Audio Codec integrated * Audio driver and utility included |
| BIOS | * Award 4MB Flash ROM |
| Multi I/O | * PS/2 keyboard and PS/2 mouse connectors * Serial port connector x1/Parallel connector x1 * VGA connectorx1 * USB2.0 port x 4 * RJ45 LAN connector x1 * Audio connector x1 (Line-in, Line-out, MIC/ 6CH Audio) * LVDS inverter connector x1 * LCD header x1 * COM header x 3 |

| | |
|--|--|
| | <ul style="list-style-type: none">* IR header x1* Wi-Fi header x1* Audio header x 1/ CDIN header x1* Front Panel header x1* Hard disk drive connector x1* SATAII connector x2 |
|--|--|

1-3 Layout Diagram

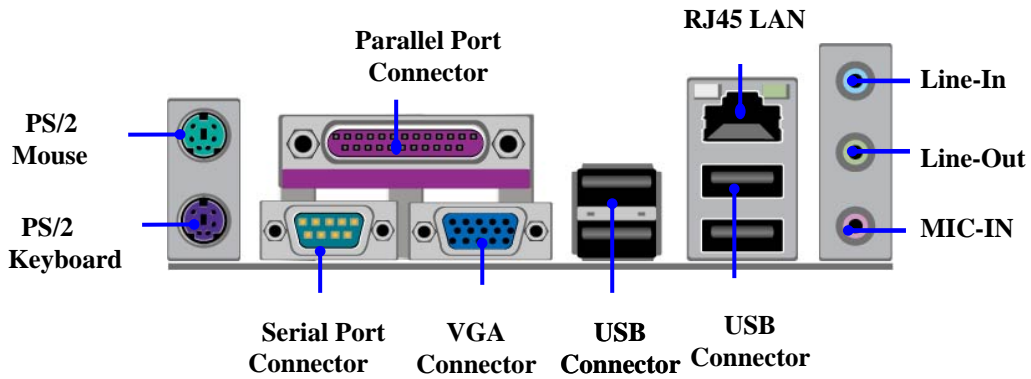

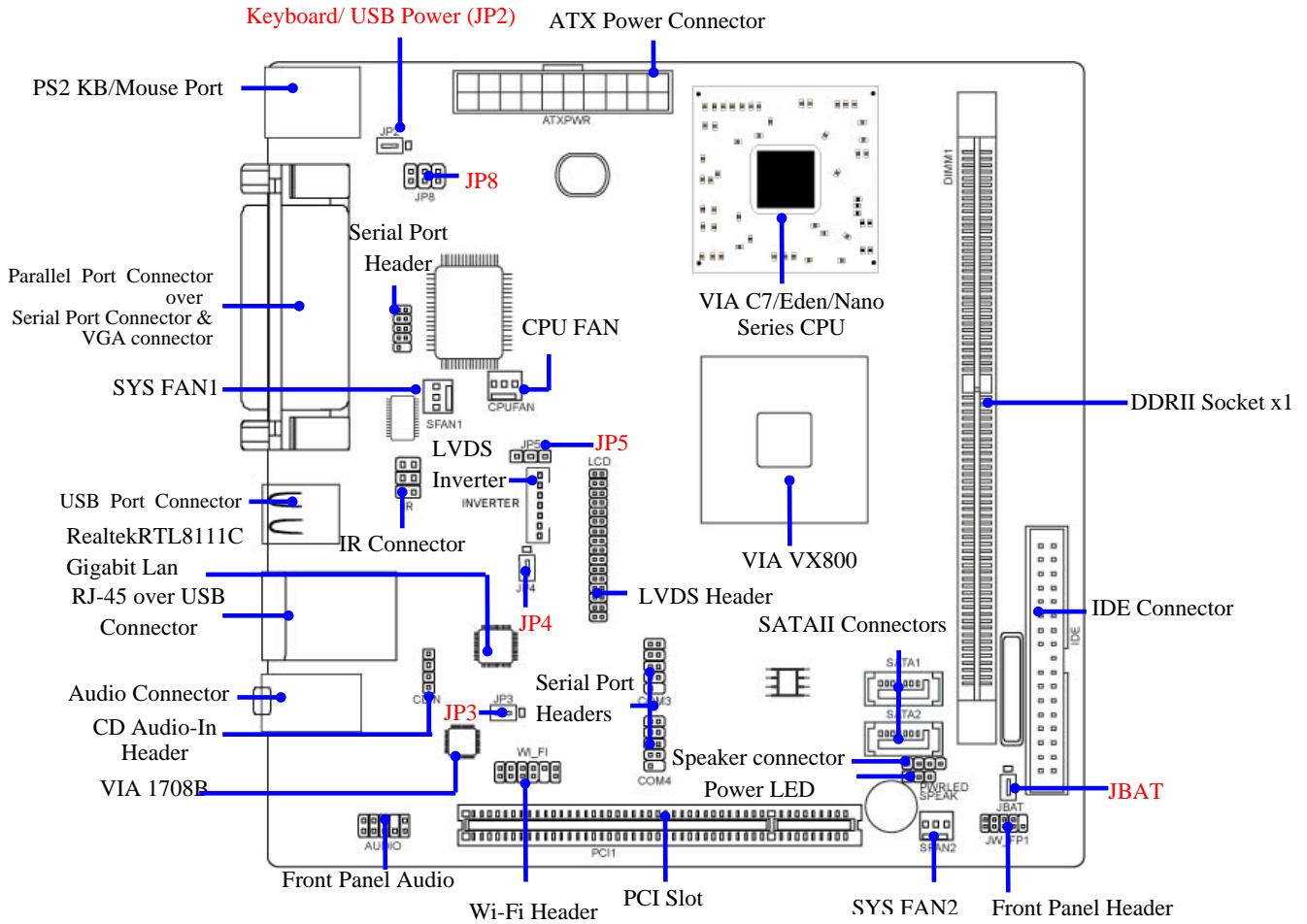

Jumper

| Jumper | Name | Description | Page |
|---------------|----------------------------------|--------------------|-------------|
| JP2 | KB/USB Power On Function Setting | 3-pin Block | P.7 |
| JBAT | CMOS RAM Clear Function Setting | 3-pin Block | P.7 |
| JP3 | USB Power On Function Setting | 3-pin Block | P.8 |
| JP4 | LVDS Voltage 5V/3.3V Select | 3-pin Block | P.8 |
| JP5 | LVDS Inverter Power On Setting | 3-pin Block | P.9 |
| JP8 | Power RS232 Function Select | 6-pin Block | P.9 |

Connectors

| Connector | Name | Description | Page |
|------------------|---------------------------------------|------------------------|-------------|
| PS2KBMS1 | Keyboard & Mouse Connector | 6-pin Female Connector | p.10 |
| COM1 | Serial Port Connector | 9-pin Connector | p.10 |
| VGA | Video Graphic Attach Connector | D-sub 15-pin Female | p.10 |
| PARALLEL | Parallel Port Connector | 25-Pin Connector | p.10 |
| USB1,USB2 | USB Port Connector | 4-pin Connector | p.10 |
| RJ-45 from UL2 | RJ-45 LAN Connector | 8-pin Connector | p.10 |
| AUDIO1 | Line-Out /MIC/Line-In Audio Connector | 3 Phone Jack | p.10 |
| IDE1 | IDE Hard Disk Drive Connector | 40-pin IDE Block | |
| SATA1,2 | Serial ATA Connectors | 7-pin Connector | |

Headers

| Header | Name | Description | Page |
|--|---|--------------------|-------------|
| AUDIO | Front panel audio Headers | 9-pin block | P.11 |
| CDIN | CD Audio-In Header | 4-pin Block | P.12 |
| COM 2, 3, 4 | Serial Port COM1 Connector | 9-pin Block | p.12 |
| WI-FI | Wi-Fi Header | 11-pin Block | P.13 |
| LCD | LVDS Connector | 32-pin Block | P.13 |
| Inverter | LVDS Inverter Connector | 7-pin Block | P.14 |
| IR | IR infrared module Headers | 5-pin Block | P.15 |
| SPEAK | Speaker Header | 3-pin Block | P.15 |
| PWR LED | Power LED | 4-pin Block | P.16 |
| JW_FP (PWR LED/ IDE LED/ /Power Button /Reset) | Front Panel Header (PWR LED/ IDE LED/ /Power Button /Reset) | 9-pin Block | P.16 |
| SFAN1, SFAN2,CPU FAN | FAN Headers | 3-pin Block | P.16 |

Chapter 2

2-1 Jumper Setting

(1) JP2: KB/USB Power On Function Setting

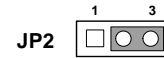
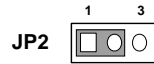
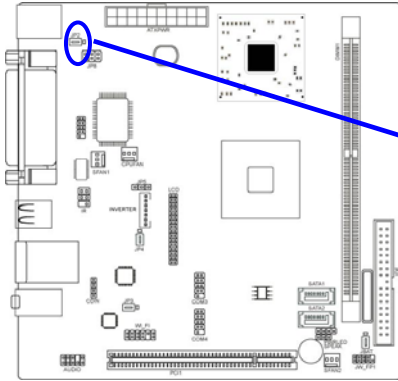

1-2 K.B&USBPOWER-ON Disacted(default) 2-3 K.B& USB POWER-ON Enabled

(2) JBAT : Clear CMOS (3-pin)

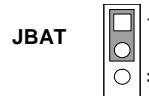
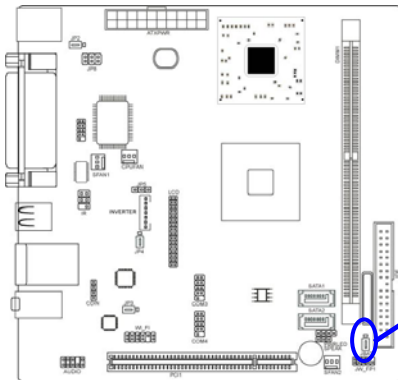

1-2 closed Normal

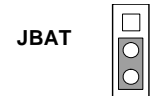

2-3 closed Clear CMOS

CMOS RAM Clear Setting

(3) JP3: USB Power On Function Setting (3-pin)

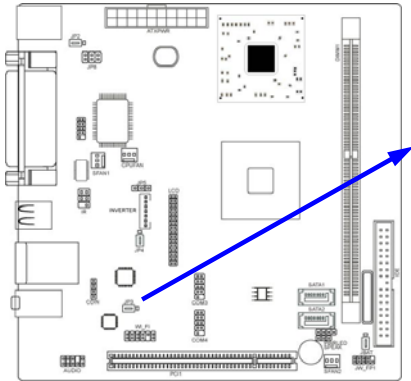

(4) JP4: LVDS VDD setting (3-pin)

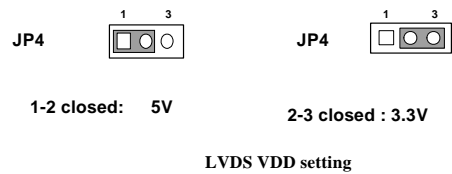
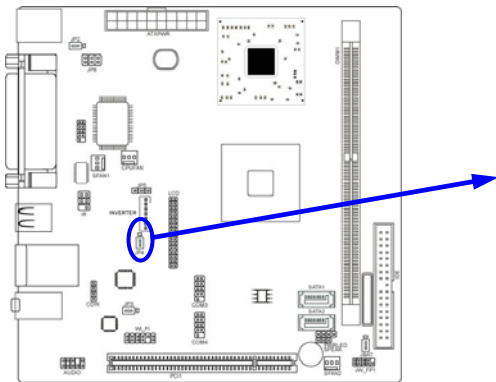

(5) JP5: LVDS Inverter Backlight Setting (3-pin)

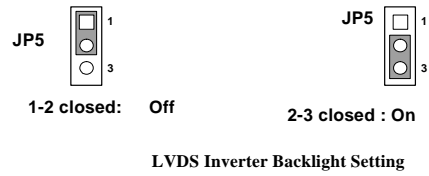
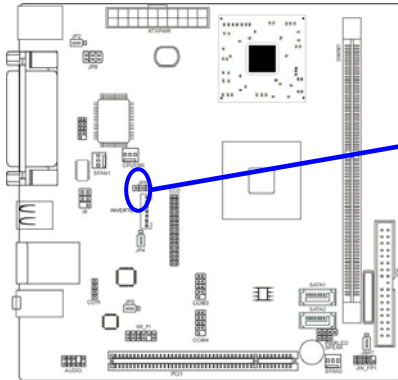

(6) JP8: Powered RS232 Function Select

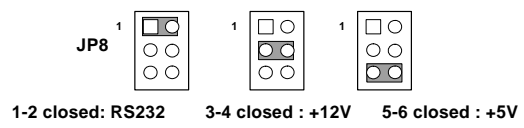
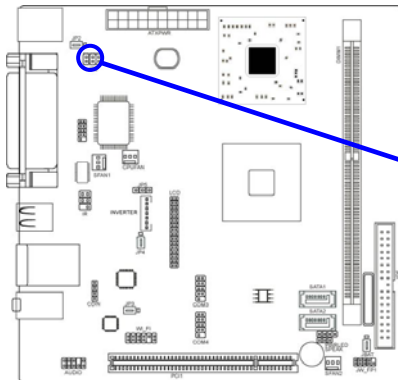

2-2 Connectors and Headers

2-2-1 Connectors

(1) I/O Back Panel Connector

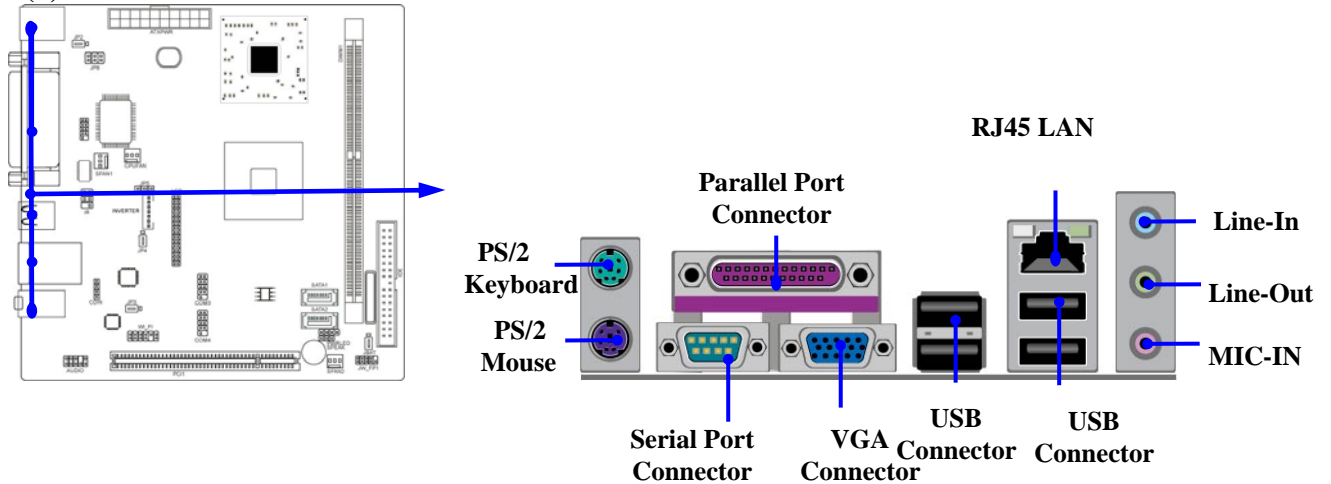

2-2-2 Headers

(1) Front panel audio header (9-pin): AUDIO

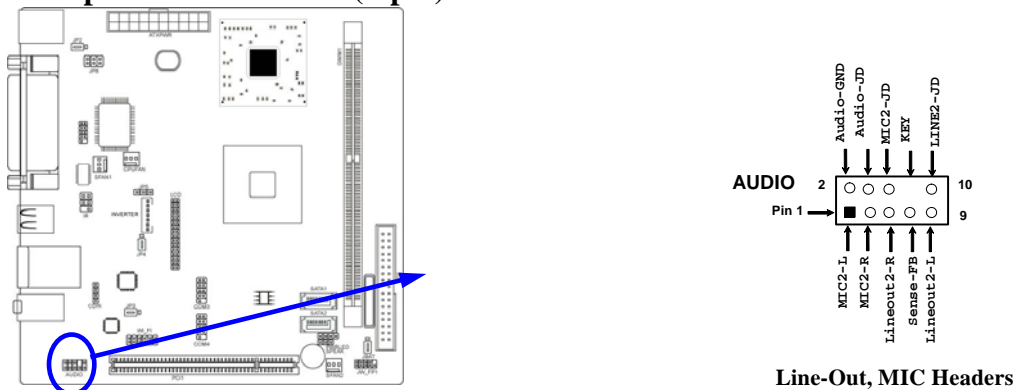

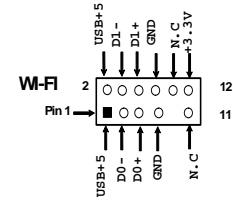
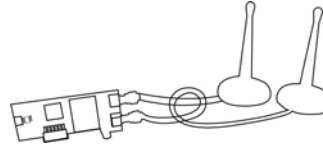
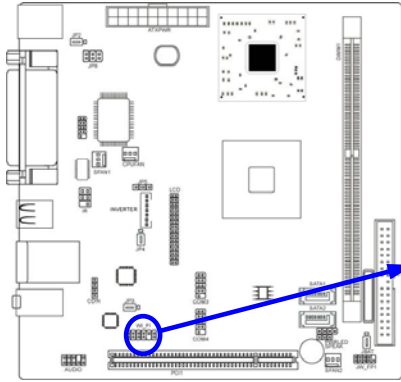

Wi-Fi Headers

(5) LVDS Headers: LCD

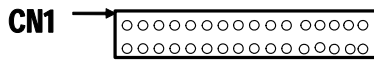
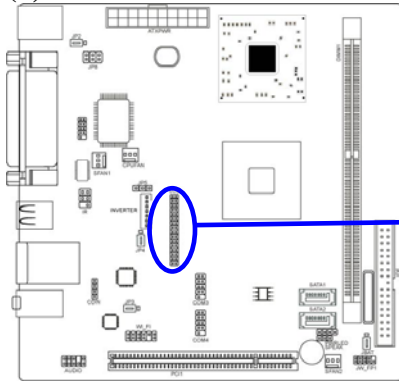

LVDS Headers

| Pin NO. | Pin Define | Pin NO. | Pin Define |
|---------|------------|---------|------------|
| Pin 1 | R2IN3- | Pin 2 | R2IN3+ |
| Pin 3 | CK2IN- | Pin 4 | CK2IN+ |
| Pin 5 | R2IN2- | Pin 6 | R2IN2+ |
| Pin 7 | R2IN1- | Pin 8 | R2IN1+ |
| Pin 9 | R2IN0- | Pin 10 | R2IN0+ |
| Pin 11 | GND | Pin 12 | GND |
| Pin 13 | GND | Pin 14 | GND |
| Pin 15 | GND | Pin 16 | GND |
| Pin 17 | R1IN3+ | Pin 18 | R1IN3- |
| Pin 19 | CK1IN+ | Pin 20 | CK1IN- |
| Pin 21 | R1IN2+ | Pin 22 | R1IN2- |
| Pin 23 | R1IN1+ | Pin 24 | R1IN1- |
| Pin 25 | R1IN0+ | Pin 26 | R1IN0- |
| Pin 27 | VDD | Pin 28 | VDD |
| Pin 29 | VDD | Pin 30 | VDD |
| Pin 31 | GND | Pin 32 | GND |

(6) Pin-headers of LVDS Inverter: INVERTER

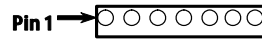
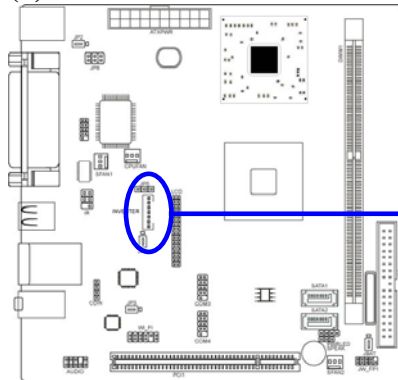

LVDS Inverter

| PIN No. | Symbol |
|---------|------------------------------------|
| 1 | +12VIN |
| 2 | +12VIN |
| 3 | GND |
| 4 | GND |
| 5 | LVDS Panel backlight enable |
| 6 | GND |
| 7 | Panel backlight brightness control |

(7) IR infrared module Headers (5-pin): IR

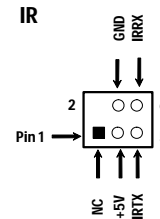
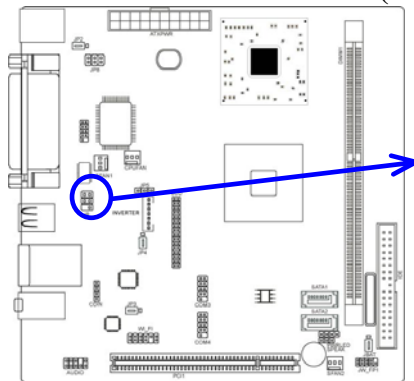

IR infrared module Header

(8) Speaker Header & Power Led Header (9-pin) : SPEAK/ PWRLED

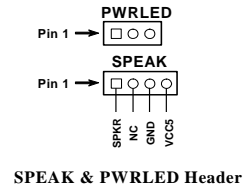
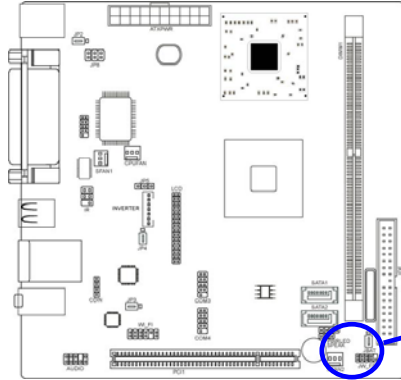

(9) Front Panel Header (9-pin) : JW_FP

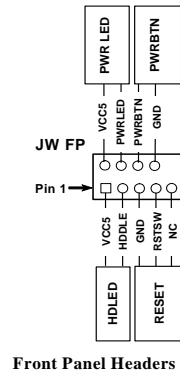
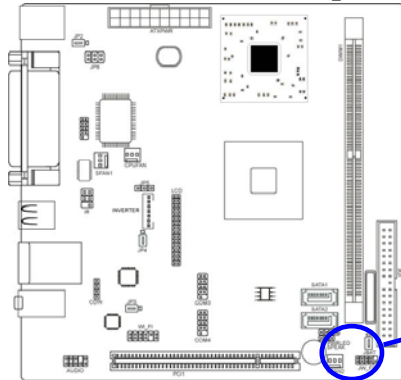

(10) FAN Speed Headers (3-pin): CPUFAN, SFAN1/SFAN2

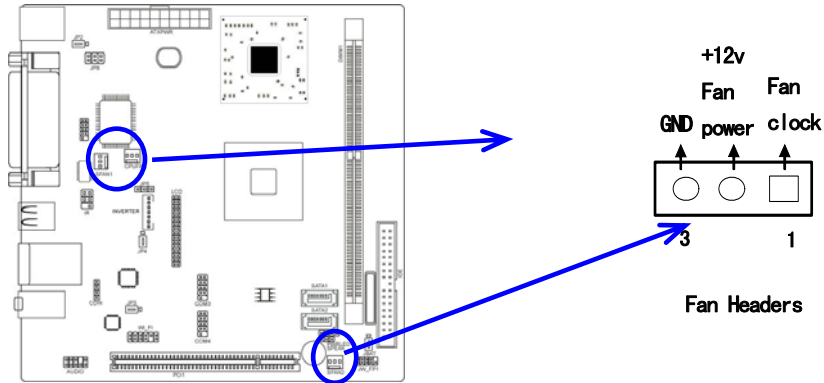

Chapter 3

Introducing BIOS

The BIOS is a program located on a Flash Memory on the motherboard. This program is a bridge between motherboard and operating system. When you start the computer, the BIOS program will gain control. The BIOS first operates an auto-diagnostic test called POST (power on self test) for all the necessary hardware, it detects the entire hardware device and configures the parameters of the hardware synchronization. Only when these tasks are completed done it gives up control of the computer to operating system (OS). Since the BIOS is the only channel for hardware and software to communicate, it is the key factor for system stability, and in ensuring that your system performance as its best.

In the BIOS Setup main menu of Figure 3-1, you can see several options. We will explain these options step by step in the following pages of this chapter, but let us first see a short description of the function keys you may use here:

- Press <Esc> to quit the BIOS Setup.

-
-
- Press ↑↓←→ (up, down, left, right) to choose, in the main menu, the option you want to confirm or to modify.
 - Press <F10> when you have completed the setup of BIOS parameters to save these parameters and to exit the BIOS Setup menu.
 - Press Page Up/Page Down or +/- keys when you want to modify the BIOS parameters for the active option.

3-1 Entering Setup

Power on the computer and by pressing immediately allows you to enter Setup.

If the message disappears before your respond and you still wish to enter Setup, restart the system to try again by turning it OFF then ON or pressing the “RESET” button on the system case. You may also restart by simultaneously pressing <Ctrl>, <Alt> and <Delete> keys. If you do not press the keys at the correct time and the system does not boot, an error message will be displayed and you will again be asked to

Press <F1> to continue, or to enter Setup

3-2 Getting Help

Main Menu

The on-line description of the highlighted setup function is displayed at the bottom of the screen.

Status Page Setup Menu/Option Page Setup Menu

Press F1 to pop up a small help window that describes the appropriate keys to use and the possible selections for the highlighted item. To exit the Help Window, press <Esc>.

3-3 The Main Menu

Once you enter Award® BIOS CMOS Setup Utility, the Main Menu (Figure 3-1) will appear on the screen. The Main Menu allows you to select from fourteen setup functions and two

exit choices. Use arrow keys to select among the items and press <Enter> to accept or enter the sub-menu.

Phoenix - AwardBIOS CMOS Setup Utility

| | |
|---------------------------|-------------------------|
| Standard CMOS Features | Miscellaneous Control |
| Advanced BIOS Features | Load Optimized Defaults |
| Advanced Chipset Features | Load standard Defaults |
| Integrated Peripherals | Set Supervisor Password |
| Power Management Setup | Set User Password |
| PnP/PCI Configurations | Save & Exit Setup |
| PC Health Status | Exit Without Saving |
| Esc : Quit | ↑↓→← : Select Item |
| F10 : Save & Exit Setup | |

Figure 3-1

Standard CMOS Features

Use this Menu for basic system configurations.

Advanced BIOS Features

Use this menu to set the Advanced Features available on your system.

Advanced Chipset Features

Use this menu to change the values in the chipset registers and optimize your system's performance.

Integrated Peripherals

Use this menu to specify your settings for integrated peripherals.

Power Management Setup

Use this menu to specify your settings for power management.

PnP/PCI Configuration

Use this menu to specify your settings for PnP and PCI configurations.

PC Health Status

This entry shows your PC health status.

Miscellaneous Control

Use this menu to specify your settings for Miscellaneous Control.

Load Optimized Defaults

Use this menu to load the BIOS default values these are setting for optimal performances system operations for performance use.

Load Standard Defaults

Use this menu to load the BIOS default values for the minimal/stable performance system operation

Set Supervisor Password

Use this menu to set supervisor password.

Set User Password

Use this menu to set user password.

Save & Exit Setup

Save CMOS value changes to CMOS and exit setup.

Exit Without Saving

Abandon all CMOS value changes and exit setup.

3-4 Standard CMOS Features

The items in Standard CMOS Setup Menu are divided into several categories. Each category includes no, one or more than one setup items. Use the arrow keys to highlight the item and then use the <PgUp> or <PgDn> keys to select the value you want in each item.

Phoenix - AwardBIOS CMOS Setup Utility
Standard CMOS Features

| | |
|---|---|
| <pre> Date (mm:dd:yy) Wed, Aug13, 2008 Time (hh:mm:ss) 16 : 48 : 35 > IDE Channel0 Master None > IDE Channel0 Slave None > IDE Channel 1 Master None > IDE Channel 1 Slave None Video EGA/VGA Halt On All, But keyboard Base Memory 1664k Extended Memory 392192k Total Memory 393216k </pre> | Item Help Menu Level > Change the day, month, year and century |
| <pre> ↑↓→← Move Enter:Select +/-/PU/PD:Value F10:Save ESC:Exit F1:General Help F5:Previous Values F6:Optimized Defaults F7:Standard Defaults </pre> | |

Date

The date format is <day><month><date><year>.

Day Day of the week is from Sun to Sat, determined by BIOS. Read-only.

Month The month is from Jan. through Dec.

Date The date from 1 to 31 can be keyed by numeric function keys.

Year The year depends on the year of the BIOS.

Time

The time format is <hour><minute><second>.

IDE Channel 0/1 Master/Slave

Press Enter and then PgUp/<+> or PgDn/<-> to select Manual, None, Auto type. Note that the specifications of your drive must match with the drive table. The hard disk will not work properly if you enter improper information for this category. If the type of hard disk drives is not matched or listed, you can use Manual to define your own drive type manually.

If you select Manual, related information is asked to be entered to the following items. Enter the information directly from the keyboard. This information should be provided in the documentation from your hard disk vendor or the system manufacturer.

If the controller of HDD interface is SCSI, the selection shall be "None".

If the controller of HDD interface is CD-ROM, the selection shall be “None”

Access Mode The settings are CHS, LBA, Large and Auto.

Cylinder number of cylinders

Head number of heads

Precomp write precomp

Landing Zone landing zone

Sector number of sectors

3-5 Advanced BIOS Features

Phoenix - AwardBIOS CMOS Setup Utility

Advanced BIOS Features

| | | | |
|---|-------------|--------------|--|
| CPU Feature | Press Enter | Item Help | |
| Hard Disk Boot Priority | Press Enter | | |
| Virus Warning | Disabled | Menu Level > | |
| CPU L1&L2 Cache | Enabled | | |
| CPU L2 Cache ECC Checking | Enabled | | |
| Quick power on self Test | Enabled | | |
| First Boot Device | CDROM | | |
| Second Boot Device | HARD DISK | | |
| Third Boot Device | LS120 | | |
| Boot other Device | Enabled | | |
| Boot Up NumLock Status | On | | |
| Typematic Rate Setting | Disabled | | |
| Typematic Rate (Chars/Sec) | 6 | | |
| Typematic Delay (Msec) | 250 | | |
| Security Option | Setup | | |
| MPS Version Control For OS | 1.4 | | |
| OS Select For DRAM > 64MB | Non-OS2 | | |
| HDD S.M.A.R.T. Capability | Disabled | | |
| Video BIOS Shadow | Enabled | | |
| ↑↓→← Move Enter:Select +/-/PU/PD:Value F10:Save ESC:Exit F1:General Help F5:Previous Values F6:Optimized Defaults F7:Standard Defaults | | | |

Hard Disk Boot Priority

The selection is for you to choose the hard disk drives priorities to boot from.

Virus Warning

The selection Allow you to choose the VIRUS Warning feature for IDE Hard Disk boot sector protection. If this function is enabled and someone attempt to write data into this area, BIOS will show a warning message on screen and alarm beep.

Disabled (default) No warning message to appear when anything attempts to access the boot sector or hard disk partition table.

Enabled Activates automatically when the system boots up causing a warning message to appear when anything attempts to access the boot sector of hard disk partition table.

CPU L1&L2 Cache

The default value is Enabled.

Enabled (default) Enable cache

Disabled Disable cache

Note: The internal cache is built in the processor.

Quick Power On Self-Test

This category speeds up Power On Self Test (POST) after you power on the computer. If this is set to Enabled, BIOS will shorten or skip some check items during POST.

Enabled (default) Enable quick POST

Disabled Normal POST

First/Second/Third Boot Device

The BIOS attempts to load the operating system from the devices in the sequence selected in these items. The optional settings are LS120, Hard disk, CDROM, ZIP100, USB-FDD, USB-ZIP, USB-CDROM, Legacy LAN and Disabled.

Boot Up NumLock Status

The default value is On.

On (default) Keypad is numeric keys.

Off Keypad is arrow keys.

Typematic Rate Setting

Keystrokes repeat at a rate determined by the keyboard controller. When enabled, the typematic rate and typematic delay can be selected. The settings are: Enabled/Disabled.

Typematic Rate (Chars/Sec)

Sets the number of times a second to repeat a keystroke when you hold the key down. The settings are: 6, 8, 10, 12, 15, 20, 24, and 30.

Typematic Delay (Msec)

Sets the delay time after the key is held down before beginning to repeat the keystroke. The settings are 250, 500, 750, and 1000.

Security Option

This category allows you to limit access to the system and Setup, or just to Setup.

System The system will not boot and access to Setup will be denied if the correct password is not entered at the prompt.

Setup (default) The system will boot, but access to Setup will be denied if the correct password is not entered prompt.

MPS Version Control for OS 1.4

This option is only valid for multiprocessor motherboards as it specifies the version of the Multiprocessor Specification (MPS) that the motherboard will use.

OS Select for DRAM > 64MB

Allows OS2[®] to be used with >64MB or DRAM. Settings are Non-OS/2 (default) and OS2. Set to OS/2 if using more than 64MB and running OS/2[®].

HDD S.M.A.R.T Capability

This option allow you to enable the HDD S.M.A.R.T Capability (Self-Monitoring, Analysis and Reporting Technology) . You can choose from Enabled and Disabled.

3-5-1 CPU Features

Phoenix - AwardBIOS CMOS Setup Utility

CPU Features

| | | |
|---|-------------------|--------------|
| Thermal Management | Thermal Monitor 2 | Item Help |
| Thermal Monitor Bus Ratio | 8x | |
| Thermal Monitor Bus VID | 1.084V | Menu Level > |
| ↑↓→← Move Enter:Select +/-/PU/PD:Value F10:Save ESC:Exit F1:General Help F5:Previous Values F6:Optimized Defaults F7:Standard Defaults | | |

Thermal Management

Thermal monitor 1 (on die throttling)

Thermal monitor 2 (Ratio&VID transition)

3-6 Advanced Chipset Features

The Advanced Chipset Features Setup option is used to change the values of the chipset registers. These registers control most of the system options in the computer.

Phoenix - AwardBIOS CMOS Setup Utility

Advanced Chipset Features

| | | |
|---|-------------|--------------|
| DRAM Timing Settings | Press Enter | Item Help |
| VGA Timing Settings | Press Enter | |
| PCI Timing Settings | Press Enter | |
| Memory Hole | Disabled | Menu Level > |
| System BIOS Cacheable | Enabled | |
| Video RAM Cacheable | Disabled | |
| ↑↓→← Move Enter:Select +/-/PU/PD:Value F10:Save ESC:Exit F1:General Help F5:Previous Values F6:Optimized Defaults F7:Standard Defaults | | |

System BIOS Cacheable

Selecting Enabled allows caching of the system BIOS ROM at F0000h-FFFFFh, resulting in better system performance. However, if any program writes to this memory area, a system error may result. The settings are: Enabled and Disabled.

3-6-1 DRAM Timing Settings

Phoenix - AwardBIOS CMOS Setup Utility

DRAM Timing Settings

| | | | |
|---|----------|---------------|--|
| Auto Configuration | By SPD | Item Help | |
| * DRAM CAS Latency (TCL) | SPD | | |
| * RAS Active Time (Tras) | 17T | Menu Level >> | |
| * ROW Precharge Time (Trp) | 5T | | |
| *RAS to CAS Delay (Trcd) | 5T | | |
| DRAM Bank Interleaving | Enabled | | |
| DDR Burst Length | SPD | | |
| DRAM Command Rate | 2T | | |
| DDR Y Table | Optimize | | |
| ODT | Disabled | | |
| ↑↓←→ Move Enter:Select +/-/PU/PD:Value F10:Save ESC:Exit F1:General Help F5:Previous Values F6:Optimized Defaults F7:Standard Defaults | | | |

Auto Configuration

The default setting is By SPD. User can set it as Manual to enable 4 sub items below it:

*DRAM CAS Latency (TCL)

The optional settings are 2T, 3T, 4T, 5T, 6T and SPD.

*RAS Active Time (Tras)

The optional settings are from 5T to 20T.

*Row Precharge Time(Trp)

The optional settings are 2T, 3T, 4T, 5T and 6T.

*RAS to CAS Delay(Trcd)

The optional settings are 2T, 3T, 4T, 5T and 6T.

DRAM Bank Interleaving

User can activate DRAM Bank Interleaving by set the item as Enabled. The optional settings are: Enabled; Disabled.

DDR Burst Length

User can set it as 4,8 or SPD. The optional setting is SPD.

DRAM Command Rate

The optional settings are: 2T; 1T.

3-6-2 VGA Timing Settings

Phoenix - AwardBIOS CMOS Setup Utility

VGA Timing Settings

| | | |
|---|----------|---------------|
| VGA Share Memory Size | 128M | Item Help |
| Direct Frame Buffer | Enabled | |
| Select Display Device | CRT | Menu Level >> |
| * Panel Type | OL | |
| -1024 x 768, chl, Dithering | Disabled | |
| *Output Port | DTO | |
| *Dithering | Disabled | |
| ↑↓→← Move Enter:Select +/-/PU/PD:Value F10:Save ESC:Exit F1:General Help F5:Previous Values F6:Optimized Defaults F7:Standard Defaults | | |

VGA Share Memory Size

The optional settings are: 64M, 128M and 256M.

Buffer Select Display Device

The options are: CRT, LCD and CRT+LCD.

3-6-3 PCI Timing Settings

Phoenix - AwardBIOS CMOS Setup Utility

PCI Timing Settings

| | | |
|---|---------|---------------|
| PCI Master0 WS Write | Enabled | Item Help |
| PCI Delay Transaction | Enabled | |
| | | Menu Level >> |
| ↑↓→← Move Enter:Select +/-/PU/PD:Value F10:Save ESC:Exit F1:General Help F5:Previous Values F6:Optimized Defaults F7:Standard Defaults | | |

3-7 Integrated Peripherals

Phoenix - AwardBIOS CMOS Setup Utility

Integrated peripheral

| | | |
|---|-------------|---------------|
| Onboard IDE Function | Press Enter | Item Help |
| Onboard Device Function | Press Enter | |
| Onboard Superio Function | Press Enter | Menu Level >> |
| USB Device Setting | Press Enter | |
| Init Display First | PCI Slot | |
| ↑↓→← Move Enter:Select +/-/PU/PD:Value F10:Save ESC:Exit F1:General Help F5:Previous Values F6:Optimized Defaults F7:Standard Defaults | | |

3-7-1 Onboard IDE Function

Phoenix - AwardBIOS CMOS Setup Utility

Onboard IDE Function

| | | |
|---|---------|---------------|
| SATA Function | Enabled | Item Help |
| SATA/RAID Mold | IDE | |
| Onchip IDE Channell | Enabled | Menu Level >> |
| IDE Predetch Mold | Enabled | |
| Secondary Master PIO | Auto | |
| Secondary Slave PIO | Auto | |
| Secondary Master UDMA | Auto | |
| Secondary Slave UDMA | Auto | |
| IDE DMA Transfer Access | Enabled | |
| IDE HDD Block Mold | Enabled | |
| ↑↓→← Move Enter:Select +/-/PU/PD:Value F10:Save ESC:Exit F1:General Help F5:Previous Values F6:Optimized Defaults F7:Standard Defaults | | |

Secondary Master/Slave PIO

The two IDE PIO (Programmed Input/Output) fields let you set a PIO mode (0-4) for each of the two IDE devices that the onboard IDE interface supports. Modes 0 through 4 provide successively increased performance. In Auto mode, the system automatically determines the best mode for each device. The settings are: Auto, Mode 0, Mode 1, Mode 2, Mode 3, Mode 4.

Secondary Master/Slave UDMA

Ultra DMA/33 implementation is possible only if your IDE hard drive supports it and the operating environment includes a DMA driver (Windows 95 OSR2 or a third-party IDE bus master driver). If your hard drive and your system software both support Ultra DMA133, select Auto to enable BIOS support. The settings are: Auto, Disabled.

IDE DMA Transfer Access

The integrated peripheral controller contains an IDE interface with support for one IDE channels. Select Enabled to activate each channel separately. The settings are: Enabled and Disabled.

IDE HDD Block Mode

Block mode is also called block transfer, multiple commands, or multiple sector read/write. If your IDE hard drive supports block mode (most new drives do), select Enabled for automatic detection of the optimal number of block read/writes per sector the drive can support. The settings are: Enabled, Disabled.

SATA Function

This item allows you to control Serial ATA controller by setting it as Enabled or Disabled.

SATA/RAID Mold

The optional settings are IDE; RAID.

3-7-2 Onboard Device Function

Phoenix - AwardBIOS CMOS Setup Utility

Onboard Device Function

| | | |
|---|----------|---------------|
| Onboard HD Audio Device | Auto | Item Help |
| Realtek Lan1 Device | Enabled | Menu Level >> |
| Realtek Lan1 Bootrom | Disabled | |
| ↑↓←→ Move Enter:Select +/-/PU/PD:Value F10:Save ESC:Exit F1:General Help F5:Previous Values F6:Optimized Defaults F7:Standard Defaults | | |

Onboard HD Audio Device

This item allows you to decide to enable/disable the chipset family to support HD Audio. The settings are: Enabled, Disabled.

RealTek LAN1 Bootrom

Decide whether to invoke the boot ROM of the onboard LAN chip.

3-7-3 Onboard Super IO Function

Phoenix - AwardBIOS CMOS Setup Utility

Onboard Super IO Function

| | | |
|---|-----------|---------------|
| Onboard Serial Port1 | 3F8/IRQ4 | Item Help |
| Onboard Serial Port2 | 2F8/IRQ3 | |
| Onboard Serial Port3 | 3E8/IRQ5 | Menu Level >> |
| Onboard Serial Port4 | 2E8/IRQ10 | |
| UART Mold Select | Normal | |
| *IR Duplex Mold | Half | |
| Onboard Parallel Port | 3F8/IRQ7 | |
| Parallel Port Mold | SPP | |
| *ECP Mold Use DMA | 3 | |
| Watchdog Timer Select | Disabled | |
| *Watchdog Timer Value | 255 | |
| *WATCHDOG Timer Unit | Sec. | |
| ↑↓→← Move Enter:Select +/-/PU/PD:Value F10:Save ESC:Exit F1:General Help F5:Previous Values F6:Optimized Defaults F7:Standard Defaults | | |

Onboard Serial Port 1/2

The optional settings are : Disabled, 3F8/IRQ4 , 2F8/IRQ3, 3E8/IRQ4 , 2E8/IRQ3, and Auto.

Onboard Serial Port 3/4

The optional settings are : Disabled, 3F8/IRQ5 , 2F8/IRQ10, 3E8/IRQ5 , 2E8/IRQ10 and Auto.

UART2 Mode Select

This item allows you to determine which InfraRed(IR) function of the onboard I/O chip. The optional settings are Normal and IrDA.

IrDA Duplex Mode

This field is available when UART Mode is set to either ASKIR or IrDA. This item enables you to determine the infrared function of the onboard infrared chip. The options are Full and Half

(default). Full-duplex means that you can transmit and send information simultaneously. Half-duplex is the transmission of data in both directions, but only one direction at a time.

Onboard Parallel Port

The optional settings are: Disabled, 378/IRQ7, 278/IRQ5 and 3BC/IRQ7.

Parallel Port Mode

SPP : Standard Parallel Port

ECP : Enhanced Com Port

EPP : Enhanced Parallel Port

SPP/ ECP +EPP 1.7/ EPP 1.9

To operate the onboard parallel port as Standard Parallel Port only, choose “SPP.” To operate the onboard parallel port in the EPP modes simultaneously, choose “EPP.” By choosing “ECP”, the onboard parallel port will operate in ECP mode only. Choosing “ECP+EPP” will allow the onboard parallel port to support both the ECP and EPP modes simultaneously. The ECP mode has to use the DMA channel, so choose the onboard parallel port with the ECP feature. After selecting it, the following message will appear: “ECP Mode Use DMA” at this time, the user can choose between DMA channels 3 to 1. The onboard parallel port is EPP Spec. compliant, so after the user chooses the onboard parallel port with the EPP function, the following message will be displayed on the screen: “EPP Mode Select.” At this time either EPP 1.7 spec. or EPP 1.9 spec. can be chosen.

Watchdog Timer Select

This item is used to activate the watchdog function. The optional settings are: Enabled; Disabled. When set it as Enabled user can choose configuration figures in subitems.

Watchdog Timer Value

This item is only activated when Watchdog Timer Select is set as Enabled and users can set a value from the range of 0~255

Watchdog Timer Unit

This item is only activated when Watchdog Timer Select is set as Enabled and the optional units are: Sec. and Min..

***Note: User needs an additional Watchdog Programming Reference Code to make use of this BIOS function. Detailed procedure please download from our website if necessary.**

3-7-4 USB Device Setting

Phoenix - AwardBIOS CMOS Setup Utility

USB Device Settings

| | | |
|---|------------|---------------|
| USB 1.0 Controller | Enabled | Item Help |
| USB 2.0 Controller | Enabled | |
| USB Operation Mold | High Speed | Menu Level >> |
| USB Keyboard Function | Enabled | |
| USB Mouse Function | Enabled | |
| USB Storage Function | Disabled | |
| ↑↓→← Move Enter:Select +/-/PU/PD:Value F10:Save ESC:Exit F1:General Help F5:Previous Values F6:Optimized Defaults F7:Standard Defaults | | |

USB 1.0/2.0 Function /Keyboard/Mouse /Storage Support

Select *Enabled* if your system contains a Universal Serial Bus (USB) controller and you have a USB mouse /keyboard/USB storage device. The settings are: Enabled, Disabled.

USB Operation Mold

The optional settings are Full/ Low Speed and High Speed.

3-8 Power Management Setup

The Power Management Setup allows you to configure your system to most effectively save energy saving while operating in a manner consistent with your own style of computer use.

Phoenix - AwardBIOS CMOS Setup Utility

Power Management Setup

| | | | |
|---|----------------|--------------|--|
| ACPI function | S1(POS) | Item Help | |
| Assign IRQ For ACPI | IRQ 9 | | |
| Video off option | Suspend-off | Menu Level > | |
| Video off Method | V/H SYNC+Blank | | |
| MODEN USE IRQ | 3 | | |
| Power Button Function | Instant off | | |
| Power Sts after power failure | Always OFF | | |
| HPET Support | Enabled | | |
| WDRT Support | Disabled | | |
| WDRT Run/stop | Stop | | |
| WDRT Count | 1023 | | |
| Wake UP Events | Press Enter | | |
| ↑↓←→ Move Enter:Select +/-/PU/PD:Value F10:Save ESC:Exit F1:General Help F5:Previous Values F6:Optimized Defaults F7:Standard Defaults | | | |

ACPI Function

The optional settings are S1(POS) and S3(STR).

Video Off Method

This determines the manner in which the monitor is blanked.

DPMS (default) Initial display power management signaling.

Blank Screen This option only writes blanks to the video buffer.

V/H SYNC+Blank This selection will cause the system to turn off the vertical and horizontal synchronization ports and write blanks to the video buffer.

MODEM Use IRQ

If you want an incoming call on a modem to automatically resume the system from a power-saving mode, use this item to specify the interrupt request line (IRQ) that is used by the modem. You might have to connect the fax/modem to the motherboard Wake On Modem connector for this feature to work.

Power Button Function

Under ACPI (Advanced Configuration and Power management Interface) you can create a software power down. In a software power down, the system can be resumed by Wake up

Alarms. This item lets you install a software power down that is controlled by the power Button on your system. If the item is set to Instant-Off, then the power button causes a software power down. If the item is set to Delay 4 Sec, then you have to hold the power button down for four seconds to cause a software power down.

Wake Up Events

Users can press Enter to select the relative items for wake up events. Set it as Disabled or Enabled in Wake-Up on LAN, Wake-Up on Ring and Wake-Up on PCI card. Users can also enter password in PS2KB Wakeup.

Wake-Up on RTC Alarm

When set to Enabled, additional fields become available and you can set the date (day of the month), hour, minute and second to turn on your system. When set to 0 (zero) for the day of the month, the alarm will power on your system every day at the specified time .

Date (of month)

You can choose which month the system will boot up. Set to 0, to boot every day.

Time (hh:mm:ss)

You can choose what hour, minute and second the system will boot up.

Note: If you have change the setting, you must let the system boot up until it goes to the operating system, before this function will work.

3-9 PnP/PCI Configuration

Phoenix - AwardBIOS CMOS Setup Utility

Pnp/PCI Configuration

| IRQ Resources | Press Enter | Item Help |
|---|-------------|--------------|
| PCI/VGA Palette Snoop | Disabled | |
| Assign IRQ For VGA | Enabled | |
| Assign IRQ For USB | Enabled | Menu Level > |
| ↑↓→← Move Enter:Select +/-/PU/PD:Value F10:Save ESC:Exit F1:General Help F5:Previous Values F6:Optimized Defaults F7:Standard Defaults | | |

PCI/VGA Palette Snoop

This item is designed to overcome problems that can be caused by some non-standard VGA cards. This board includes a built-in VGA system that does not require palette snooping so you must leave this item disabled.

IRQ Resources

Names the interrupt request (IRQ) line assigned to the USB on your system. Activity of the selected IRQ always awakens the system.

3-10 PC Health Status

This section shows the Status of you CPU, Fan, and Warning for overall system status. This is only available if there is Hardware Monitor onboard.

Phoenix - AwardBIOS CMOS Setup Utility

PC Health Status

| | | |
|---|-------------|--------------|
| Shutdown Temperature | Disabled | Item Help |
| Show PC Health In Post | Enabled | |
| CPU Thermal-Throttling | Disabled | Menu Level > |
| * CPU Thermal-Throttling Temp | 70c | |
| * CPU Thermal-Throttling Duty | 50% | |
| * CPU Thermal-Throttling Beep | Enabled | |
| Smart fan configurations | Press Enter | |
| Vcore | 1.10v | |
| +1.5v | 1.52v | |
| +5v | 4.81v | |
| +12v | 12.07v | |
| +5VSB | 4.98V | |
| VDIMM | 1.84V | |
| VCC3 | 3.44V | |
| 3.3 SUS | 3.36V | |
| VBAT | 3.23V | |
| CPU Temperature | 20C/69F | |
| SYS Temperature | 16C/69F | |
| CPU FAN Speed | 6607 RPM | |
| SYS FAN1 Speed | 0RPM | |
| SYS FAN2 Speed | 0RPM | |
| ↑↓→← Move Enter:Select +/-/PU/PD:Value F10:Save ESC:Exit F1:General Help F5:Previous Values F6:Optimized Defaults F7:Standard Defaults | | |

Show PC Health in Post

During Enabled, it displays information list below. The choice is either Enabled or Disabled

Shutdown Temperature

This item can let users setting the Shutdown temperature, when CPU temperature over this setting the system will auto shutdown to protect CPU.

Current CPU Temperature/Current System Temp/Current SFAN1, SFAN2 ,CPUFAN Speed/Vcore/ +1.5V/+5V/+12V/+5 VSB(V) /VDIMM/VCC3/3.3SUS/VBAT(V)

This will show the CPU/FAN/System voltage chart and FAN Speed.

3-11 Miscellaneous Control

Phoenix - AwardBIOS CMOS Setup Utility

Miscellaneous Control

| | | |
|---|----------------|--------------|
| Auto Detect PCI CLK | Enabled | Item Help |
| Spread Spectrum | Disabled | |
| *** Current Host Frequency is 100MHz*** | | Menu Level > |
| CPU Clock at Next boot is | 100MHz | |
| ***Current DRAM Frequency is 333MHz*** | | |
| DRAM Clock at Next Boot is | SPD | |
| CPU Clock Ratio | 8X | |
| Vcore voltage | Default | |
| VCC1.05 Voltage | 1.05v(Default) | |
| VCC 1.5 Voltage | 1.50v(Default) | |
| VDIMM Voltage | 1.84v(Default) | |
| ↑↓→← Move Enter:Select +/-/PU/PD:Value F10:Save ESC:Exit F1:General Help F5:Previous Values F6:Optimized Defaults F7:Standard Defaults | | |

Auto Detect PCI Clock

This item allows you to enable/disable auto detect PCI Clock. The settings are: Enabled, Disabled.

Spread Spectrum

This item allows you to set the Spread Spectrum Disabled or choose a setting in the category of +/-0.1%~ +/-0.9%.

CPU Clock at Next Boot

Users can Page Up and Page Down or change the value. The optional range is from 100 MHz to 133MHz.

DRAM Clock at Next Boot

This item allows you to set DRAM clock. The optional settings are: DDR400; DDR533; DDR667 and SPD.

3-12 Password Setting

You can set either supervisor or user password, or both of them. The differences are:

Supervisor password: Can enter and change the options of the setup menus.

User password: Can only enter but do not have the right to change the options of the setup menus. When you select this function, the following message will appear at the center of the screen to assist you in creating a password.

ENTER PASSWORD:

Type the password, up to eight characters in length, and press <Enter>. The password typed now will clear any previously entered password from CMOS memory. You will be asked to confirm the password. Type the password again and press <Enter>. You may also press <Esc> to abort the selection and not enter a password.

To disable a password, just press <Enter> when you are prompted to enter the password. A message will confirm that the password will be disabled. Once the password is disabled, the system will boot and you can enter Setup freely.

PASSWORD DISABLED.

When a password has been enabled, you will be prompted to enter it every time you try to enter Setup. This prevents an unauthorized person from changing any part of your system configuration.

Additionally, when a password is enabled, you can also require the BIOS to request a password every time your system is rebooted. This would prevent unauthorized use of your computer.

You determine when the password is required within the BIOS Features Setup Menu and its Security option. If the Security option is set to “System”, the password will be required both at boot and at entry to Setup. If set to “Setup”, prompting only occurs when trying to enter Setup.

3-13 Load Standard/Optimized Defaults

Load Standard Defaults

When you press <Enter> on this item, you get confirmation dialog box with a message similar to:

Load Standard Defaults (Y/N)? N

Pressing <Y> loads the BIOS default values for the most stable, minimal-performance system operations.

Load Optimized Defaults

When you press <Enter> on this item, you get a confirmation dialog box with a message similar to:

Load Optimized Defaults (Y/N)? N

Pressing <Y> loads the default values that are factory settings for optimal performance system operations.