



# EMC COMPLIANCE TEST REPORT

For

## Motherboard

**Trade Name** : JETWAY  
**Model Number** : J7F4B1G5D (Please see P7 for all the trade names and model numbers)  
**Serial Number** : N/A  
**Report Number** : SZ061031B05-ET  
**Date** : December 29, 2006  
**Regulations** : See below

Standards	Results (Pass/Fail)
EN 55022: 1998+A1:2000+A2:2003	PASS
EN 61000-3-2: 2000	PASS
EN 61000-3-3: 1995+A1:2001	PASS
EN 55024: 1998+A1:2001+A2:2003	
- IEC 61000-4-2: 2001	PASS
- IEC 61000-4-3: 2002	PASS
- IEC 61000-4-4: 2001	PASS
- IEC 61000-4-5: 2001	PASS
- IEC 61000-4-6: 2001	PASS
- IEC 61000-4-11: 2001	PASS

Prepared for :

**JET WAY INFORMATION CO., LTD**

**4F, NO.168, LITEHST, CHUNG AO CITY 235, TAIPEI, TAIWAN R.O.C**

Prepared by :

**COMPLIANCE CERTIFICATION SERVICES (SHENZHEN) INC.**

**NO.5 JINAO INDUSTRIAL PARK, NO.35 JUKENG ROAD,**

**DASHUIKENG VILLAGE, GUANLAN TOWN,**

**BAOAN DISTRICT, SHENZHEN, CHINA**

**TEL:86-755-28055000**

**FAX:86-755-28055221**



LAB CODE:200577-0

*Note: This report shall not be reproduced except in full, without the written approval of Compliance Certification Service Inc. . This document may be altered or revised by Compliance Certification Service Inc. personnel only, and shall be noted in the revision section of the document.*



## TABLE OF CONTENTS

DESCRIPTION	PAGE
TEST RESULT CERTIFICATION	4
GENERAL INFORMATION	5
SYSTEM DESCRIPTION	6
PRODUCT INFORMATION	7
SUPPORT EQUIPMENT	8
TEST FACILITY	9
TEST EQUIPMENT LIST	10
<b>SECTION 1 EN 55022(LINE CONDUCTED &amp; RADIATED EMISSION)</b>	12
MEASUREMENT PROCEDURE & LIMIT (LINE CONDUCTED EMISSION TEST)	12
MEASUREMENT PROCEDURE & LIMIT (RADIATED EMISSION TEST)	15
BLOCK DIAGRAM OF TEST SETUP	17
SUMMARY DATA	18
<b>SECTION 2 EN 61000-3-2 &amp; EN 61000-3-3 (POWER HARMONICS &amp; VOLTAGE FLUCTUATION/FLICKER)</b>	21
RESULT	21
<b>SECTION 3 IEC 61000-4-2 (ELECTROSTATIC DISCHARGE)</b>	26
BLOCK DIAGRAM OF TEST SETUP	26
TEST PROCEDURE	27
PERFORMANCE & RESULT	28
DISCHARGE POINTS OF EUT	29
<b>SECTION 4 IEC 61000-4-3 (RADIATED ELECTROMAGNETIC FIELD)</b>	30
BLOCK DIAGRAM OF TEST SETUP	30
TEST PROCEDURE	31
PERFORMANCE & RESULT	31



<b>DESCRIPTION</b>	<b>PAGE</b>
<b>SECTION 5 IEC 61000-4-4 (FAST TRANSIENTS/BURST)</b>	32
BLOCK DIAGRAM OF TEST SETUP	32
TEST PROCEDURE	33
PERFORMANCE & RESULT	33
<b>SECTION 6 IEC 61000-4-5 (SURGE IMMUNITY)</b>	34
BLOCK DIAGRAM OF TEST SETUP	34
TEST PROCEDURE	35
PERFORMANCE & RESULT	35
<b>SECTION 7 IEC 61000-4-6 (CONDUCTED DISTURBANCE/ INDUCED BY RADIO-FREQUENCY FIELD)</b>	36
BLOCK DIAGRAM OF TEST SETUP	36
TEST PROCEDURE	37
PERFORMANCE & RESULT	37
<b>SECTION 8 IEC 61000-4-11 (VOLTAGE DIPS,SHORT INTERRUPTIONS AND VOLTAGE VARIATIONS)</b>	38
BLOCK DIAGRAM OF TEST SETUP	38
TEST PROCEDURE	39
PERFORMANCE & RESULT	39
APPENDIX 1 PHOTOGRAPHS OF TEST SETUP	40



# TEST RESULT CERTIFICATION

**Equipment Under Test:** Motherboard  
**Trade Name:** JETWAY  
**Model Number:** J7F4B1G5D (Please see P7 for all the trade names and model numbers)  
**Serial Number:** N/A  
**Applicant:** JET WAY INFORMATION CO., LTD  
 4F, NO.168, LITEHST, CHUNG AO CITY 235, TAIPEI, TAIWAN R.O.C  
**Manufacturer 1:** TOP WAY TCHNOLOGY CO., LTD  
 SHANG JIN INDUSTRIAL ZONE JIE KOU VILLAGE CHANG AN  
 TOWN DONG GUAN CITY GUANG DONG PROVINCE P.R.C  
**Manufacturer 2:** EVER ORIENT TECHNOLOGY CO., LTD  
 LIAN HE INDUSTRIAL PARK, NAN YUE, LONG GONG, SHENZHEN,  
 GUANG DONG, CHINA.  
**Manufacturer 3:** RIGHT TRACK ELECTRONIC TECHNOLOGY CO., LTD  
 NO.2 WEST WORDSHOP, NO.1 DISTRICT NANCHANG INDUSTRIAL  
 ZONE, GUSHU VILLIAGE, XIXIANG TOWN, BAOAN, SHENZHEN,  
 P.R.CHINA.  
**Type of Test:** EMC Directive 89/336/EEC for CE Marking  
**Technical Standards:** EN 55022: 1998+A1: 2000+A2: 2003  
 EN 61000-3-2: 2000  
 EN 61000-3-3: 1995+A1: 2001  
 EN 55024: 1998+A1: 2001+A2: 2003  
 (IEC 61000-4-2: 2001; IEC 61000-4-3: 2002;  
 IEC 61000-4-4: 2001; IEC 61000-4-5: 2001;  
 IEC 61000-4-6: 2001; IEC 61000-4-11: 2001)  
**Report Number:** SZ061031B05-ET  
**Date of test:** October 31~December 28, 2006  
**Deviation:** None  
**Condition of Test Sample:** Normal

The above equipment was tested by Compliance Certification Services (Shenzhen) Inc. for compliance with the requirements set forth in EMC Directive 89/336/EEC amended by 93/68/EEC and the Technical Standards mentioned above. This said equipment in the configuration described in this report shows the maximum emission levels emanating from equipment and the level of the immunity endurance of the equipment are within the compliance requirements.

The test results of this report relate only to the tested sample identified in this report.

Approved By:

Tested By: Jason He

Clinton Kao / Manager  
COMPLIANCE CERTIFICATION  
SERVICES (SHENZHEN) INC.

Reviewed By:

Vincent Yao / Assistant manager  
COMPLIANCE CERTIFICATION  
SERVICES (SHENZHEN) INC.



## GENERAL INFORMATION

**Applicant:** JET WAY INFORMATION CO., LTD  
4F, NO.168, LITEHST, CHUNG AO CITY 235, TAIPEI, TAIWAN R.O.C

**Manufacturer 1:** TOP WAY TECHNOLOGY CO., LTD  
SHANG JIN INDUSTRIAL ZONE JIE KOU VILLAGE CHANG AN  
TOWN DONG GUAN CITY GUANG DONG PROVINCE P.R.C

**Manufacturer 2:** EVER ORIENT TECHNOLOGY CO., LTD  
LIAN HE INDUSTRIAL PARK, NAN YUE, LONG GONG, SHENZHEN,  
GUANG DONG, CHINA.

**Manufacturer 3:** RIGHT TRACK ELECTRONIC TECHNOLOGY CO., LTD  
NO.2 WEST WORDSHOP, NO.1 DISTRICT NANCHANG INDUSTRIAL  
ZONE, GUSHU VILLIAGE, XIXIANG TOWN, BAOAN, SHENZHEN,  
P.R.CHINA.

**Report Number:** SZ061031B05-ET

**Date of Test:** October 31~December 28, 2006

**Equipment Under Test:** Motherboard

**Model Number:** J7F4B1G5D (Please see P7 for all the trade names and model numbers)

**Serial Number:** N/A

**Type of Test:** EMC Directive 89/336/EEC for CE Marking

**Technical Standards:** EN 55022: 1998+A1: 2000+A2: 2003  
EN 61000-3-2: 2000  
EN 61000-3-3: 1995+A1: 2001  
EN 55024: 1998+A1: 2001+A2: 2003  
(IEC 61000-4-2: 2001; IEC 61000-4-3: 2002;  
IEC 61000-4-4: 2001; IEC 61000-4-5: 2001;  
IEC 61000-4-6: 2001; IEC 61000-4-11: 2001)

**Frequency Range  
(EN 55022):** 150kHz to 30MHz for Line Conducted Test  
30MHz to 1000MHz for Radiated Emission Test

**Test Site** Compliance Certification Services (Shenzhen) Inc.  
No. 5, Jinao industrial park, No.35 Jukeng Road, Dashuikeng Village,  
Guanlan Town, Baoan District, Shenzhen, China



## **SYSTEM DESCRIPTION**

### **EUT Test Program:**

1. Set up with the auxiliary equipments, then run the EMCTEST.EXE program in windows XP mode.
2. Make sure the EUT is full load during the test.



### PRODUCT INFORMATION

**Housing Type:** Metal

**EUT Power Rating:** DC5V or DC12V supplied by PC

**Power during Test:** DC5V or DC12V supplied by PC

**Data Cable:** N/A

**I/O Port of EUT:**

I/O Port Type	Q'TY	Tested with
1) USB Port	4	4
2) PS/2 Port	2	2
3) RJ45 Port	2	2
4) MIC Port	1	1
5) Audio Port	2	2
6) VGA Port	1	1
7) DB9 Port	1	1

**Difference between model numbers as below:**

	Model Number	Trade Name
1.	J7F4B1G5D	JETWAY
2.	J7F4XYYYY ("X" can be "B" or "K"; "YYYY" can be "0" to "9", "A" to "Z" or blank)	

**SUPPORT EQUIPMENT**

No.	Equipment	Model #	Serial #	Trade Name	Data Cable	Power Cord
1.	LCD MONITOR	VP201B	A21050102549	VIEWSONIC	Shielded 1.8 m	Unshielded 1.8m
2.	MODEM	SUPERFAX6.0	9013593	ACEEX	Shielded 1.5m	Unshielded 1.8m
3.	PRINTER	C8942A	TH19T1G0W4	HP	Shielded 1.5m	Unshielded 1.8m
4.	PS/2 KEYBOARD	SK-8115	CN-0J4633-71616-5 1A-0KJY	DELL	Shielded 1.6m	N/A
5.	PS/2 MOUSE	M-S69	323614-001	HP	Shielded 1.8 m	N/A
6.	RJ45 CABLE 1	N/A	N/A	N/A	Unshielded 1.2m	N/A
7.	USB CABLE 1	N/A	N/A	N/A	Unshielded 1.5m	N/A
8.	USB CABLE 2	N/A	N/A	N/A	Unshielded 1.5m	N/A
9.	USB CABLE 3	N/A	N/A	N/A	Unshielded 1.5m	N/A
10.	USB CABLE 4	N/A	N/A	N/A	Unshielded 1.5m	N/A
11.	AUDIO CABLE 1	N/A	N/A	N/A	Unshielded 1.2m	N/A
12.	AUDIO CABLE 2	N/A	N/A	N/A	Unshielded 1.2m	N/A
13.	MIC CABLE	N/A	N/A	N/A	Unshielded 1.2m	N/A
14.	HD	M6FYA	24094LFJHMER	MAXTOR	N/A	N/A
15.	PC POWER	ST-ATX340	B6058518	SHIJIZHIXING	N/A	N/A
16.	PC BOX	N/A	51200136	SHIJIZHIXING	N/A	N/A
17.	MEMORY EXPERT	DDR-0035	R670070T	V-DATA	N/A	N/A
18.	CPU	C7-D 1500/400	D6D0T002SB0	TAIWAN	N/A	N/A
19.	CPU FAN	DFB401012M	N/A	YOUNG LIN	N/A	N/A

**\*\*Note:** All the above equipment/cables were placed in worse case positions to maximize emission signals during emission test.

**Grounding:** Grounding was in accordance with the manufacturer's requirements and conditions for the intended use.



## TEST FACILITY

- Location:** No. 5, Jinao industrial park, No.35 Jukeng Road, Dashuikeng Village, Guanlan Town, Baoan District Shenzhen, China.
- Description:** There is one 3/10m open area test sites and one line conducted labs for final test.  
The Open Area Test Sites and the Line Conducted labs are constructed and calibrated to meet the FCC requirements in documents ANSI C63.4 and CISPR 22/EN 55022 requirements.
- Site Filing:** A site description is on file with the Federal Communications Commission, 7435 Oakland Mills Road, Columbia, MD 21046.
- Site Accreditation:** Accredited by Nemko ( Aut. No.: ELA106), VCCI(Registration No.: R-1996,C-2150), FCC ( Registration No.: 101879) and NVLAP(Lab code:200577-0) for EMC.
- Instrument Tolerance:** All measuring equipment is in accord with ANSI C63.4 and CISPR 22 requirements that meet industry regulatory agency and accreditation agency requirement.
- Ground Plane:** Two conductive reference ground planes were used during the Line Conducted Emission, one in vertical and the other in horizontal. The dimensions of these ground planes are as below. The vertical ground plane was placed distancing 40 cm to the rear of the wooden test table on where the EUT and the support equipment were placed during test. The horizontal ground plane projected 50 cm beyond the footprint of the EUT system and distanced 80 cm to the wooden test table. For Radiated Emission Test, one horizontal conductive ground plane extended at least 1m beyond the periphery of the EUT and the largest measuring antenna, and covered the entire area between the EUT and the antenna. It has no holes or gaps having longitudinal dimensions larger than one-tenth of a wavelength at the highest frequency of measurement up to 1GHz.



## TEST EQUIPMENT LIST

**Instrumentation:** The following list contains equipment used at Compliance Certification Services (Shenzhen) Inc. for testing. The equipment conforms to the CISPR 16-1 / ANSI C63.2 Specifications for Electromagnetic Interference and Field Strength Instrumentation from 10kHz to 1.0GHz or above.

**Equipment used during the tests:**

Open Area Test Site: G

Open Area Test Site G					
EQUIPMENT TYPE	MFR	MODEL NUMBER	SERIAL NUMBER	LAST CAL.	CAL. DUE
EMI Test Receiver	ROHDE&SCHWARZ	ESCI	100145	02/09/2006	02/08/2007
Pre Amplifier	H.P.	8447D	2944A06833	09/01/2006	09/01/2007
Bi-log Antenna	SCHAFFNER	CBL6143	5082	06/10/2006	06/09/2007
Cable	TIME MICROWAVE	LMR-400	N-TYPE04	06/10/2006	06/09/2007
System-Controller	CT	SC100	N/A	N/A	N/A
Turn Table	EMCO	2081-1.21	N/A	N/A	N/A
Antenna Tower	CT	N/A	N/A	N/A	N/A
DECOUPLING NETWORK	FISCHER CUSBENGE	F-201-DCN-5-6MM	12	06/10/2006	06/09/2007

*Note: The measure uncertainty is less than +/-2.5078dB, which is evaluated as per the UKAS LAB34 and CISPR/A/291/CDV.*

Conducted Emission Test Site: G

Conducted Emission Test Site G					
EQUIPMENT TYPE	MFR	MODEL NUMBER	SERIAL NUMBER	LAST CAL.	CAL. DUE
EMI Test Receiver	ROHDE&SCHWARZ	ESCI	100088	02/09/2006	02/08/2007
LISN	EMCO	3825/2	1371	02/09/2006	02/08/2007
LISN	EMCO	3825/2	8901-1459	02/09/2006	02/08/2007

*Note: The measure uncertainty is less than +/-2.2318dB, which is evaluated as per the UKAS LAB34 and CISPR/A/291/CDV.*

The calibrations of the measuring instruments, including any accessories that may effect such calibration, are checked frequently to assure their accuracy. Adjustments are made and correction factors applied in accordance with instructions contained in the manual for the measuring instrument.

**TEST EQUIPMENT LIST**

<b>Power Harmonic &amp; Voltage Fluctuation/Flicker Measurement (61000-3-2&amp;3-3)</b>					
<b>EQUIPMENT TYPE</b>	<b>MFR</b>	<b>MODEL NUMBER</b>	<b>SERIAL NUMBER</b>	<b>LAST CAL.</b>	<b>CAL DUE.</b>
Harmonic & Flicker Tester	SCHAFFNER	CCN1000	720465	02/09/2006	02/08/2007
Power Source	SCHAFFNER	NSG1007	54789	02/09/2006	02/08/2007

<b>ESD test (61000-4-2)</b>					
<b>EQUIPMENT TYPE</b>	<b>MFR</b>	<b>MODEL NUMBER</b>	<b>SERIAL NUMBER</b>	<b>LAST CAL.</b>	<b>CAL DUE.</b>
ESD 30 System	EM Test	ESD 30C	1202-17	10/17/2006	10/16/2007

<b>Radiated Electromagnetic Field immunity Measurement (61000-4-3)</b>					
<b>EQUIPMENT TYPE</b>	<b>MFR</b>	<b>MODEL NUMBER</b>	<b>SERIAL NUMBER</b>	<b>LAST CAL.</b>	<b>CAL DUE.</b>
Signal Generator	Maconi	2022D	119246/003	06/10/2006	06/09/2007
Power Amplifier	MIS	A00181-1000	9801-112	06/10/2006	06/09/2007
Power Amplifier	MIS	AC8113/ 800-250A	9801-179	06/10/2006	06/09/2007
Power Antenna	SCHAFFNER	CBL6140A	1204	06/10/2006	06/09/2007

<b>Fast Transients/Burst test (61000-4-4)/Surge(61000-4-5)/Voltage Dips &amp; Interruptions(61000-4-11)</b>					
<b>EQUIPMENT TYPE</b>	<b>MFR</b>	<b>MODEL NUMBER</b>	<b>SERIAL NUMBER</b>	<b>LAST CAL.</b>	<b>CAL DUE.</b>
Fast Transients/Burst Generator	SCHAFFNER	BEST EMC V2.7	200126-012S C	02/09/2006	02/08/2007

<b>CS test (61000-4-6)</b>					
<b>EQUIPMENT TYPE</b>	<b>MFR</b>	<b>MODEL NUMBER</b>	<b>SERIAL NUMBER</b>	<b>LAST CAL.</b>	<b>CAL DUE.</b>
Signal Generator	Maconi	2022D	119246/003	06/10/2006	06/09/2007
Power Amplifier	MIS	A00181-1000	9801-112	06/10/2006	06/09/2007
CDN	MEB	M3-8016	003683	06/10/2006	06/09/2007



**SECTION 1 EN 55022(LINE CONDUCTED AND RADIATED EMISSION) MEASUREMENT PROCEDURE (PRELIMINARY LINE CONDUCTED EMISSION TEST)**

- 1) The equipment was set up as per the test configuration to simulate typical actual usage per the user’s manual. When the EUT is a tabletop system, a wooden table with a height of 0.8 meters is used and is placed on the ground plane as per EN55022 (see Test Facility for the dimensions of the ground plane used). When the EUT is a floor-standing equipment, it is placed on the ground plane which has a 3-12 mm non-conductive covering to insulate the EUT from the ground plane.
2) Support equipment, if needed, was placed as per EN55022.
3) All I/O cables were positioned to simulate typical actual usage as per EN55022.
4) The EUT received DC power from PC power supply, and PC received AC230V/50Hz power through a Line Impedance Stabilization Network (LISN) which supplied power source and was grounded to the ground plane.
5) All support equipments received power from a second LISN supplying power of AC230V/50Hz, if any.
6) The EUT test program was started. Emissions were measured on each current carrying line of the EUT using a spectrum Analyzer / Receiver connected to the LISN powering the EUT. The LISN has two monitoring points: Line 1 (Hot Side) and Line 2 (Neutral Side). Two scans were taken: one with Line 1 connected to Analyzer / Receiver and Line 2 connected to a 50 ohm load; the second scan had Line 1 connected to a 50 ohm load and Line 2 connected to the Analyzer / Receiver.
7) Analyzer / Receiver scanned from 150kHz to 30MHz for emissions in each of the test modes.
8) During the above scans, the emissions were maximized by cable manipulation.
9) The following test mode(s) were scanned during the preliminary test:

Table with 4 columns: Frequency Range Investigated, Mode of operation, Date, Data Report No., Worst Mode. Row 1: Full Cable, 2006-12-27, J7F4B1G5D\_0(L, N), X

Then, the EUT configuration and cable configuration of the above highest emission level were recorded for reference of final testing.



### MEASUREMENT PROCEDURE (FINAL LINE CONDUCTED EMISSION TEST)

- 1) EUT and support equipment was set up on the test bench as per step 9 of the preliminary test.
- 2) A scan was taken on both power lines, Line 1 and Line 2, recording at least the six highest emissions. Emission frequency and amplitude were recorded into a computer in which correction factors were used to calculate the emission level and compare reading to the applicable limit. If EUT emission level was less -2dB to the A.V. limit in Peak mode, then the emission signal was re-checked using Q.P and Average detector.
- 3) The test data of the worst case condition(s) was reported on the Summary Data page.

**Data Sample:**

Freq. MHz	Peak Raw dBuV	Q.P. Raw dBuV	Average Raw dBuV	Q.P. Limit dBuV	Average Limit dBuV	Q.P. Margin dB	Average Margin dB	Note
XX.XXX	43.90	---	---	56.00	46.00	---	-2.10	L 1

- Freq. = Emission frequency in MHz
- Raw dBuV = Uncorrected Analyzer/Receiver reading
- Limit dBuV = Limit stated in standard
- Margin dB = Reading in reference to limit
- Note = Current carrying line of reading
- “---“ = The emission level complied with the Average limits, with at least 2 dB margin, so no further recheck.



## LINE CONDUCTED EMISSION LIMIT

Frequency	Maximum RF Line Voltage	
	Q.P.( dBuV)	AVERAGE( dBuV)
150kHz-500kHz	66-56	56-46
500kHz-5MHz	56	46
5MHz-30MHz	60	50

**\*\*Note:** The lower limit shall apply at the transition frequency.



### MEASUREMENT PROCEDURE (PRELIMINARY RADIATED EMISSION TEST)

- 1) The equipment was set up as per the test configuration to simulate typical actual usage per the user’s manual. When the EUT is a tabletop system, a wooden turntable with a height of 0.8 meters is used which is placed on the ground plane as per EN 55022 (see Test Facility for the dimensions of the ground plane used).When the EUT is a floor-standing equipment, it is placed on the ground plane which has a 3-12 mm non-conductive covering to insulate the EUT from the ground plane.
- 2) Support equipment, if needed, was placed as per EN 55022.
- 3) All I/O cables were positioned to simulate typical actual usage as per EN 55022.
- 4) The EUT received DC power from PC power supply, and PC received AC230V/50Hz power through the outlet socket under the turntable. All support equipments received AC 230V/50Hz power from socket under the turntable, if any.
- 5) The antenna was placed at 10 meter away from the EUT as stated in EN 55022. The antenna connected to the Analyzer via a cable and at times a pre-amplifier would be used.
- 6) The Analyzer / Receiver quickly scanned from 30MHz to 1000MHz. The EUT test program was started. Emissions were scanned and measured rotating the EUT to 360 degrees and positioning the antenna 1 to 4 meters above the ground plane, in both the vertical and the horizontal polarization, to maximize the emission reading level.
- 7) The following test mode(s) were scanned during the preliminary test:

<b>Preliminary Radiated Emission Test</b>			
Frequency Range Investigated		30 MHz TO 1000 MHz	
Mode of operation	Date	Data Report No.	Worst Mode
Full Cable	2006-12-25	J7F4B1G5D_0(H, V)	<input checked="" type="checkbox"/>

Then, the EUT and cable configuration, antenna position, polarization and turntable position of the above highest emission level were recorded for final testing.



### MEASUREMENT PROCEDURE (FINAL RADIATED EMISSION TEST)

- 1) EUT and support equipment were set up on the turntable as per step 7 of the preliminary test.
- 2) The Analyzer / Receiver scanned from 30MHz to 1000MHz. Emissions were scanned and measured rotating the EUT to 360 degrees, varying cable placement and positioning the antenna 1 to 4 meters above the ground plane, in both the vertical and the horizontal polarization, to maximize the emission reading level.
- 3) Recorded at least the six highest emissions. Emission frequency, amplitude, antenna position, polarization and turntable position were recorded into a computer in which correction factors were used to calculate the emission level and compare reading to the applicable limit and Q.P./Peak reading is presented.
- 4) The test data of the worst case condition(s) was reported on the Summary Data page.

**Data Sample:**

Freq. (MHz)	Raw Data (dBuV/m)	Corr. Factor (dB)	Emiss. Level ( dBuV/m )	Limits	Margin (dB)	Reading Type P/Q
xx.xxx	14.03	12.25	26.28	30.00	-3.72	P

- Freq. = Emission frequency in MHz
- Raw Data (dBuV/m) = Uncorrected Analyzer / Receiver reading
- Corr. Factor (dB) = Correction factors of antenna factor and cable loss
- Emiss. Level = Raw reading converted to dBuV/m and CF added
- Limit dBuV/m = Limit stated in standard
- Margin dB = Reading in reference to limit
- P =Peak Reading
- Q =Quasi-peak



## RADIATED EMISSION LIMIT

Frequency (MHz)	Distance (m)	Maximum Field Strength Limit (dBuV/m/ Q.P.)
30-230	10	30.00
230-1000	10	37.00

**\*\*Note:** The lower limit shall apply at the transition frequency.

## BLOCK DIAGRAM OF TEST SETUP

### System Diagram of Connections between EUT and Simulators

**EUT :** Motherboard

**Trade Name :** JETWAY

**Model Number:** J7F4B1G5D

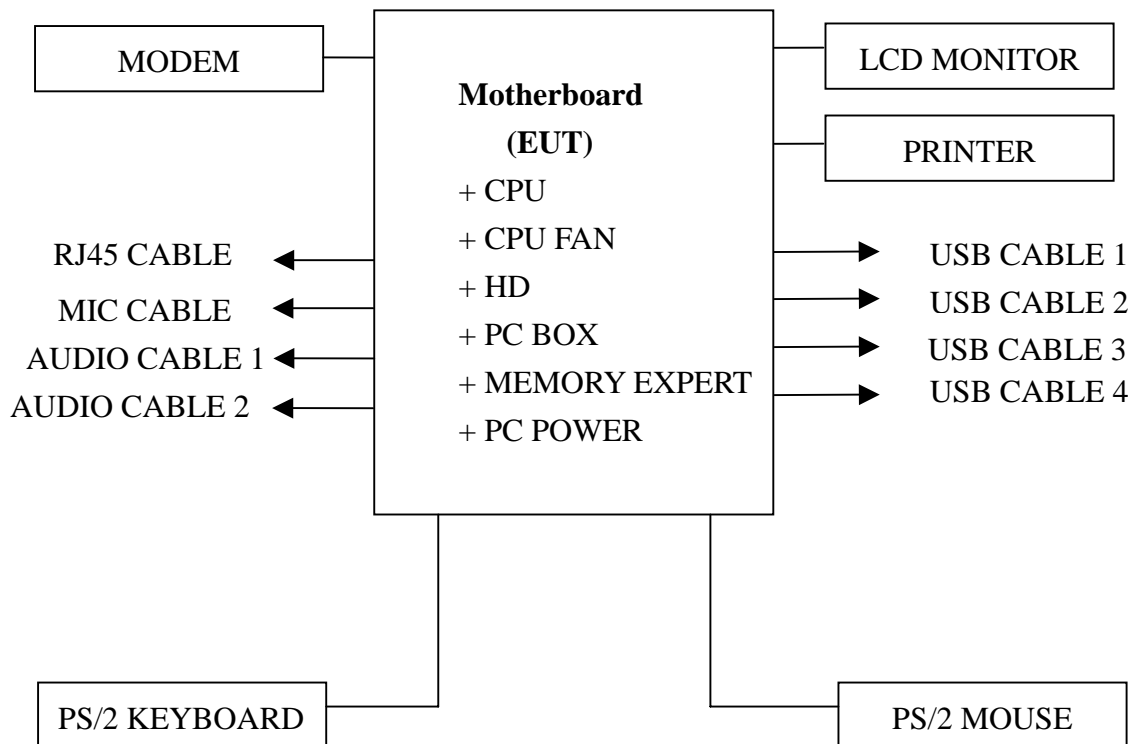



### SUMMARY DATA

#### (LINE CONDUCTED TEST)

**Model Number:** J7F4B1G5D

**Tested by:** Jason

**Location:** Site G

**Test Mode:** Full Cable

**Test Results:** Passed

**Temperature:** 25°C

**Humidity:** 56%RH

(The chart below shows the highest readings taken from the final data)

FREQ MHz	PEAK RAW dBuV	Q.P. RAW dBuV	AVG RAW dBuV	Q.P. Limit dBuV	AVG Limit dBuV	Q.P. Margin dB	AVG Margin dB	NOTE
0.168	56.62	54.98	45.42	65.47	55.47	-10.49	-10.05	L1
0.231	46.98	---	---	63.67	53.67	---	-6.69	L1
0.302	43.90	---	---	61.66	51.66	---	-7.76	L1
0.368	44.43	---	---	59.75	49.75	---	-5.32	L1
0.439	50.86	48.95	35.94	57.74	47.74	-8.79	-11.80	L1
1.062	33.23	---	---	56.00	46.00	---	-12.77	L1
0.168	54.65	47.87	38.37	65.47	55.47	-17.60	-17.10	L2
0.235	45.98	---	---	63.56	53.56	---	-7.58	L2
0.368	44.73	42.89	30.48	59.75	49.75	-16.86	-19.27	L2
0.439	50.19	47.60	35.22	57.74	47.74	-10.14	-12.52	L2
1.058	31.45	---	---	56.00	46.00	---	-14.55	L2
4.621	32.18	---	---	56.00	46.00	---	-13.82	L2

L1 = Line One (Hot side) / L2 = Line Two (Neutral side)

**\*\*NOTE:** “---” denotes the emission level was or more than 2dB below the Average limit, so no re-check anymore.



## SUMMARY DATA

### (RADIATED EMISSION TEST)

**Model Number:** J7F4B1G5D**Location:** Site G**Tested by:** Jason**Test Mode:** Full Cable**Polar:** Vertical / Horizontal**Test Results:** Passed**Test Distance:** 10m**Temperature:** 25°C**Humidity:** 56%RH

(The chart below shows the highest readings taken from the final data)

Frequency Range Investigated (30 MHz TO 1000 MHz)							
Freq (MHz)	Meter Reading (dBuV/m)	CF (dBuV/m)	Corrected Reading (dBuV/m)	Limits (dBuV/m)	Margin (dB)	Reading Type P/Q	Pol. H/V
132.540	33.88	-6.97	26.91	30.00	-3.09	Q	V
166.650	34.52	-8.50	26.02	30.00	-3.98	P	V
297.200	31.74	-3.53	28.21	37.00	-8.79	P	V
433.200	27.33	-1.28	26.05	37.00	-10.95	P	V
534.040	29.81	1.09	30.90	37.00	-6.10	P	V
601.490	29.00	-0.27	28.73	37.00	-8.27	P	V
132.590	32.41	-4.93	27.48	30.00	-2.52	P	H
231.110	30.43	-0.68	29.75	37.00	-7.25	P	H
503.270	28.67	-1.14	27.53	37.00	-9.47	P	H
533.940	33.75	1.00	34.75	37.00	-2.25	Q	H
562.450	26.35	1.89	28.24	37.00	-8.76	P	H
594.130	27.25	1.29	28.54	37.00	-8.46	P	H

$C.F.(\text{Correction Factor}) = \text{Antenna Factor} + \text{Cable Loss} - \text{Amplifier Gain} (+ \text{Attenuator } 6\text{dB})$

$\text{Corrected Reading} = \text{Metering Reading} + C.F.$

$\text{Margin} = \text{Corrected Reading} - \text{Limits}$

$P = \text{Peak Reading}$

$H = \text{Horizontal Polarization/Antenna}$

$Q = \text{Quasi-peak}$

$V = \text{Vertical Polarization/Antenna}$

Comments: N/A

## SECTION 2 EN 61000-3-2 & EN 61000-3-3 (POWER HARMONICS & VOLTAGE FLUCTUATION / FLICKER)

### POWER HARMONICS MEASUREMENT

**Port** : AC mains  
**Basic Standard** : EN 61000-3-2 :2000  
**Limits** :  CLASS A ;  CLASS D  
**Temperature** : 25°C  
**Humidity** : 56%

### VOLTAGE FLUCTUATION/FLICKER MEASUREMENT

**Port** : AC mains  
**Basic Standard** : EN 61000-3-3 : 1995+A1:2001  
**Limits** : §5 of EN 61000-3-3  
**Temperature** : 25°C  
**Humidity** : 56%

### Block Diagram of Test Setup:

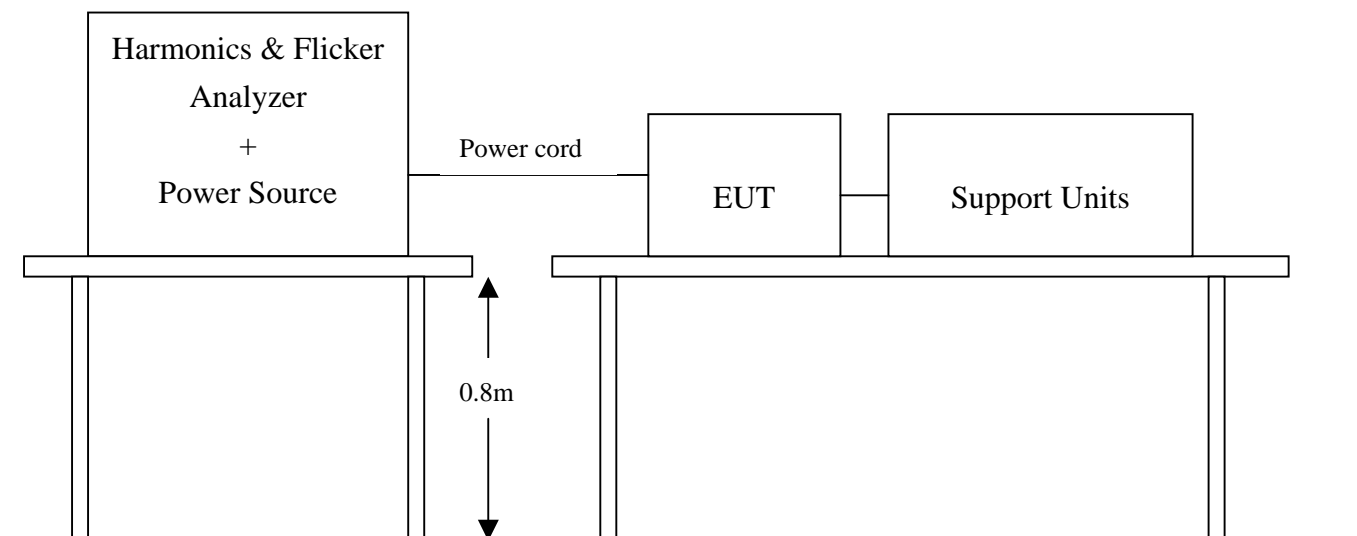

### Result:

Please see the attached test data



## Harmonics – Class-D

EUT: Motherboard

Test category: Class-D (European limits)

Test date: 2006-12-25

Start time: 10:22:41

Tested by: Jason

Test Margin: 100

End time: 10:25:21

Test duration (min): 2.5

Data file name: H-000164.cts\_data

Comment: J7F4B1G5D

Customer: JET WAY INFORMATION CO., LTD

Test Result: Pass

Source qualification: Normal

### Current & voltage waveforms

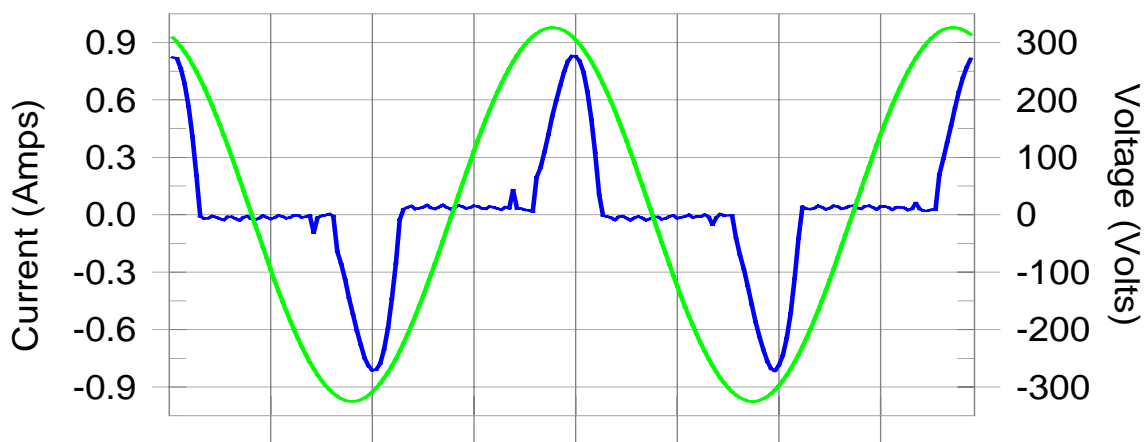

### Harmonics and Class D limit line

### European Limits

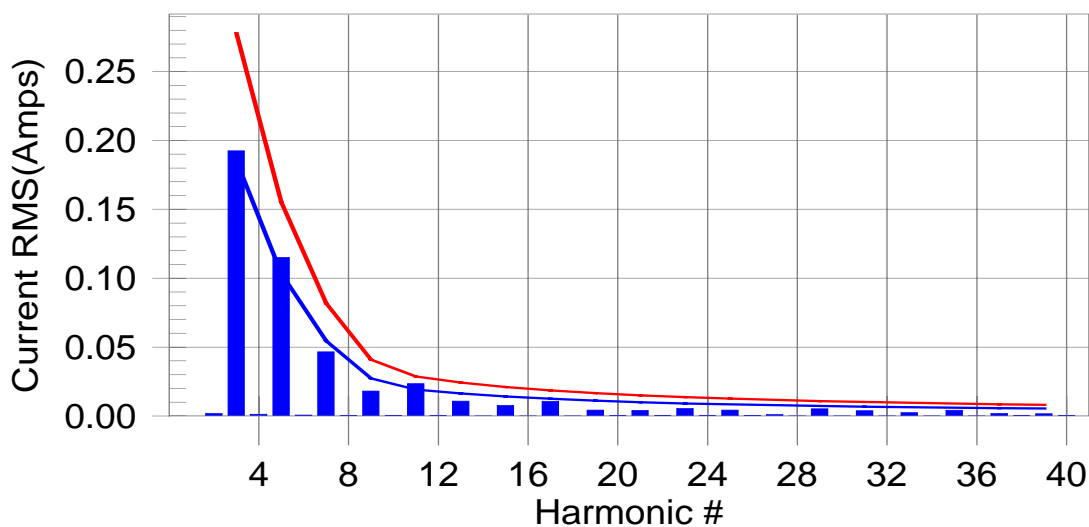

Test result: Pass Worst harmonic was #0 with 0.00% of the limit.



### Current Test Result Summary

EUT: Motherboard Tested by: Jason  
 Test category: Class-D (European limits) Test Margin: 100  
 Test date: 2006-12-25 Start time: 10:22:41 End time: 10:25:21  
 Test duration (min): 2.5 Data file name: H-000164.cts\_data  
 Comment: J7F4B1G5D  
 Customer: JET WAY INFORMATION CO., LTD

Test Result: Pass Source qualification: Normal  
 THC(A): 0.00 I-THD(%): 0.00 POHC(A): 0.000 POHC Limit(A): 0.000

Highest parameter values during test:

V_RMS (Volts):	230.19	Frequency(Hz):	50.00
I_Peak (Amps):	0.837	I_RMS (Amps):	0.335
I_Fund (Amps):	0.240	Crest Factor:	2.511
Power (Watts):	54.5	Power Factor:	0.709

Harm#	Harms(avg)	100%Limit	%of Limit	Harms(max)	150%Limit	%of Limit	Status
2	0.002						
3	0.189	0.185	0.0	0.192	0.278	0.00	Pass
4	0.001						
5	0.114	0.104	0.0	0.115	0.155	0.00	Pass
6	0.001						
7	0.045	0.055	0.0	0.047	0.082	0.00	Pass
8	0.000						
9	0.018	0.027	0.0	0.018	0.041	0.00	Pass
10	0.000						
11	0.023	0.019	0.0	0.023	0.029	0.00	Pass
12	0.000						
13	0.011	0.016	0.0	0.011	0.024	0.00	Pass
14	0.000						
15	0.007	0.014	0.0	0.008	0.021	0.00	Pass
16	0.000						
17	0.010	0.013	0.0	0.011	0.019	0.00	Pass
18	0.000						
19	0.004	0.011	0.0	0.004	0.017	0.00	Pass
20	0.000						
21	0.004	0.010	0.0	0.004	0.015	0.00	Pass
22	0.000						
23	0.005	0.009	0.0	0.005	0.014	0.00	Pass
24	0.000						
25	0.004	0.008	0.0	0.004	0.013	0.00	Pass
26	0.000						
27	0.001	0.008	0.0	0.001	0.012	0.00	Pass
28	0.000						
29	0.005	0.007	0.0	0.005	0.011	0.00	Pass
30	0.000						
31	0.004	0.007	0.0	0.004	0.010	0.00	Pass
32	0.000						
33	0.002	0.006	0.0	0.002	0.010	0.00	Pass
34	0.000						
35	0.004	0.006	0.0	0.004	0.009	0.00	Pass
36	0.000						
37	0.002	0.006	0.0	0.002	0.009	0.00	Pass
38	0.000						
39	0.001	0.005	0.0	0.002	0.008	0.00	Pass
40	0.000						

Note: The EUT power level is below 75.0 Watts and therefore has no defined limits



### Voltage Source Verification Data

EUT: Motherboard Tested by: Jason  
 Test category: Class-D (European limits) Test Margin: 100  
 Test date: 2006-12-25 Start time: 10:22:41 End time: 10:25:21  
 Test duration (min): 2.5 Data file name: H-000164.cts\_data  
 Comment: J7F4B1G5D  
 Customer: JET WAY INFORMATION CO., LTD

Test Result: Pass Source qualification: Normal

Highest parameter values during test:

Voltage (Vrms):	230.19	Frequency(Hz):	50.00
I_Peak (Amps):	0.837	I_RMS (Amps):	0.335
I_Fund (Amps):	0.240	Crest Factor:	2.511
Power (Watts):	54.5	Power Factor:	0.709

Harm#	Harmonics V-rms	Limit V-rms	% of Limit	Status
2	0.123	0.460	26.74	OK
3	0.542	2.071	26.19	OK
4	0.133	0.460	28.98	OK
5	0.077	0.921	8.38	OK
6	0.073	0.460	15.78	OK
7	0.056	0.690	8.10	OK
8	0.051	0.460	11.16	OK
9	0.044	0.460	9.60	OK
10	0.050	0.460	10.78	OK
11	0.047	0.230	20.33	OK
12	0.036	0.230	15.75	OK
13	0.035	0.230	15.19	OK
14	0.026	0.230	11.09	OK
15	0.027	0.230	11.79	OK
16	0.027	0.230	11.81	OK
17	0.023	0.230	9.77	OK
18	0.027	0.230	11.77	OK
19	0.027	0.230	11.53	OK
20	0.023	0.230	10.14	OK
21	0.025	0.230	10.73	OK
22	0.018	0.230	7.91	OK
23	0.019	0.230	8.25	OK
24	0.016	0.230	6.80	OK
25	0.018	0.230	7.83	OK
26	0.019	0.230	8.41	OK
27	0.014	0.230	6.21	OK
28	0.017	0.230	7.57	OK
29	0.022	0.230	9.65	OK
30	0.016	0.230	7.01	OK
31	0.013	0.230	5.46	OK
32	0.015	0.230	6.46	OK
33	0.014	0.230	5.93	OK
34	0.011	0.230	4.80	OK
35	0.016	0.230	7.02	OK
36	0.011	0.230	4.71	OK
37	0.009	0.230	3.78	OK
38	0.009	0.230	3.81	OK
39	0.011	0.230	4.81	OK
40	0.011	0.230	4.82	OK



### Flicker Test Summary

EUT: Motherboard

Tested by: Jason

Test category: All parameters (European limits)

Test Margin: 100

Test date: 2006-12-25

Start time: 10:29:40

End time: 10:40:01

Test duration (min): 10

Data file name: F-000165.cts\_data

Comment: J7F4B1G5D

Customer: JET WAY INFORMATION CO., LTD

Test Result: Pass

Status: Test Completed

#### Pst, and limit line

#### Japanese Limits

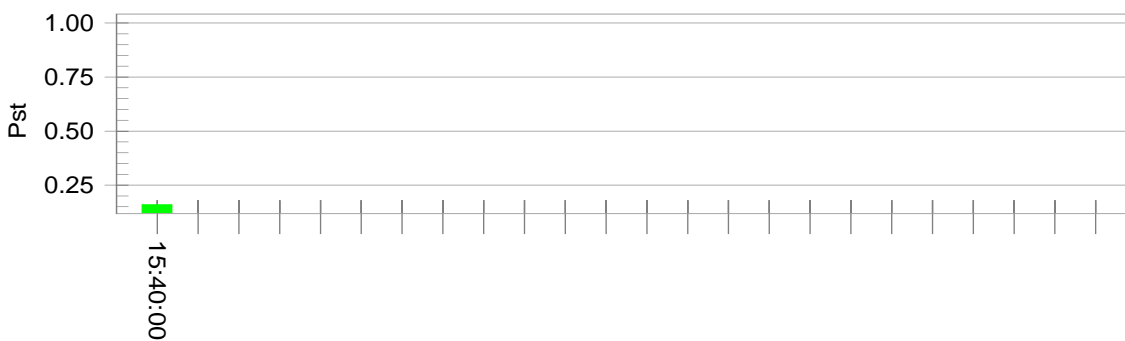

#### Plt and limit line

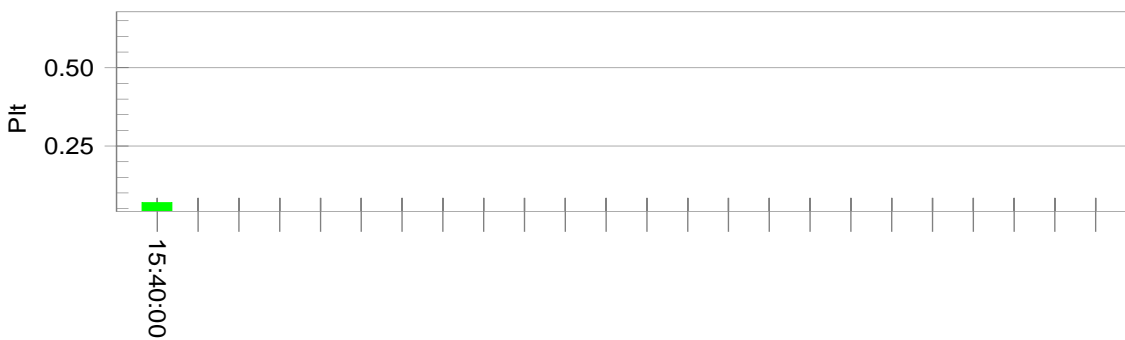

#### Parameter values recorded during the test:

Vrms at the end of test (Volt):	229.89			
Highest dt (%):	0.13	Test limit (%):	3.30	Pass
Time(mS) > dt:	0.0	Test limit (mS):	500.0	Pass
Highest dc (%):	0.00	Test limit (%):	3.30	Pass
Highest dmax (%):	0.09	Test limit (%):	4.00	Pass
Highest Pst (10 min. period):	0.160	Test limit:	1.000	Pass
Highest Plt (2 hr. period):	0.070	Test limit:	0.650	Pass

## SECTION 3 IEC 61000-4-2 (ELECTROSTATIC DISCHARGE)

### ELECTROSTATIC DISCHARGE (ESD) IMMUNITY TEST

**Port** : Enclosure  
**Basic Standard** : IEC 61000-4-2: 2001  
**Test Level** :  $\pm 8$  kV (Air Discharge)  
                    $\pm 4$  kV (Contact Discharge)  
**Performance Criterion** : B ( Standard require )  
**Temperature/Humidity** : 25°C/55%

#### Block Diagram of Test Setup:

( The 470 k ohm resistors are installed per standard requirement )

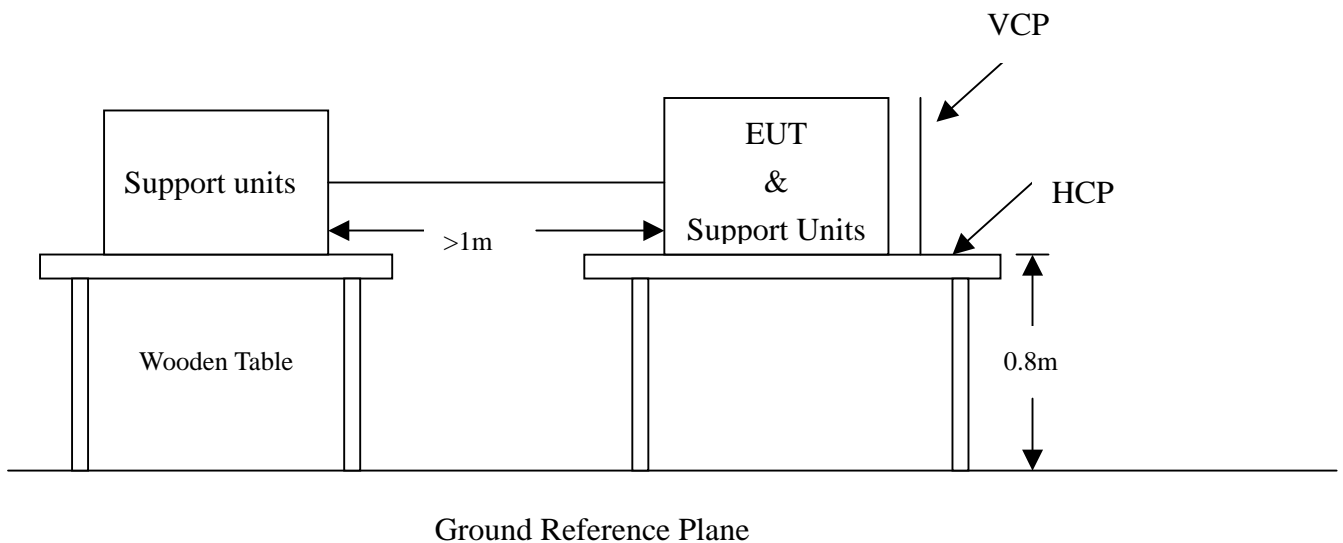



**Test Procedure:**

1. The EUT was located 0.1 m minimum from all side of the HCP.
2. The support units were located 1 m minimum away from the EUT.
3. Set up with the auxiliary equipments, then run the EMCTEST.EXE program in windows XP mode. Make sure the EUT is full load during the test.
4. Active the communication function if the EUT with such port(s).
5. As per the requirement of EN 55024; applying direct contact discharge at the sides other than front of EUT at minimum 50 discharges (25 positive and 25 negative) if applicable, can't be applied direct contact discharge side of EUT then the indirect discharge shall be applied. One of the test points shall be subjected to at least 50 indirect discharge (contact) to the front edge of horizontal coupling plane.
6. Other parts of EUT where it is not possible to perform contact discharge then selecting appropriate points of EUT for air discharge, a minimum of 10 single air discharges shall be applied.
7. The application of ESD to the contact of open connectors is not required.
8. Putting a mark on EUT to show tested points. The following test condition was followed during the tests.

**Note:** As per the A2 to IEC 61000-4-2, a bleed resistor cable is connected between the EUT and HCP during the test.

The electrostatic discharges were applied as follows:

Amount of Discharges	Voltage	Coupling	Result (Pass/Fail)
Mini 25 /Point	±2kV; ±4kV	Contact Discharge	Pass
Mini 25 /Point	±2kV; ±4kV	Indirect Discharge HCP (Front)	Pass
Mini 25 /Point	±2kV; ±4kV	Indirect Discharge VCP (Left)	Pass
Mini 25 /Point	±2kV; ±4kV	Indirect Discharge VCP (Back)	Pass
Mini 25 /Point	±2kV; ±4kV	Indirect Discharge VCP (Right)	Pass
Mini 10 /Point	±2kV; ±4kV; ±8kV	Air Discharge	No discharge Point

**The discharge points to EUT, please refer to attached pages.**

**(Blue arrow mark for contact discharge, red arrow mark for air discharge.)**



**Performance & Result:**

- Criterion A:** The apparatus continues to operate as intended. No degradation of performance or loss of function is allowed below a performance level specified by the manufacturer, when the apparatus is used as intended. In some cases the performance level may be replaced by a permissible loss of performance.
- Criterion B:** The apparatus continues to operate as intended after the test. No degradation of performance or loss of function is allowed below a performance level specified by the manufacturer, when the apparatus is used as intended. In some cases the performance level may be replaced by a permissible loss of performance. During the test, degradation of performance is however allowed.
- Criterion C:** Temporary loss of function is allowed, provided the functions self recoverable or can be restored by the operation of controls.

<input checked="" type="checkbox"/> <b>PASS</b> <input type="checkbox"/> <b>FAIL</b>
--

## *Discharge points of EUT*



**SECTION 4 IEC 61000-4-3 (RADIATED ELECTROMAGNETIC FIELD )  
RADIATED ELECTROMAGNETIC FIELD IMMUNITY TEST**

**Port** : Enclosure  
**Basic Standard** : IEC 61000-4-3:2002  
**Requirements** : 3 V/m with 80% AM. 1kHz Modulation.  
**Performance Criterion** : A ( Standard require )  
**Temperature** : 25°C  
**Humidity** : 56%

**Block Diagram of Test Setup:**

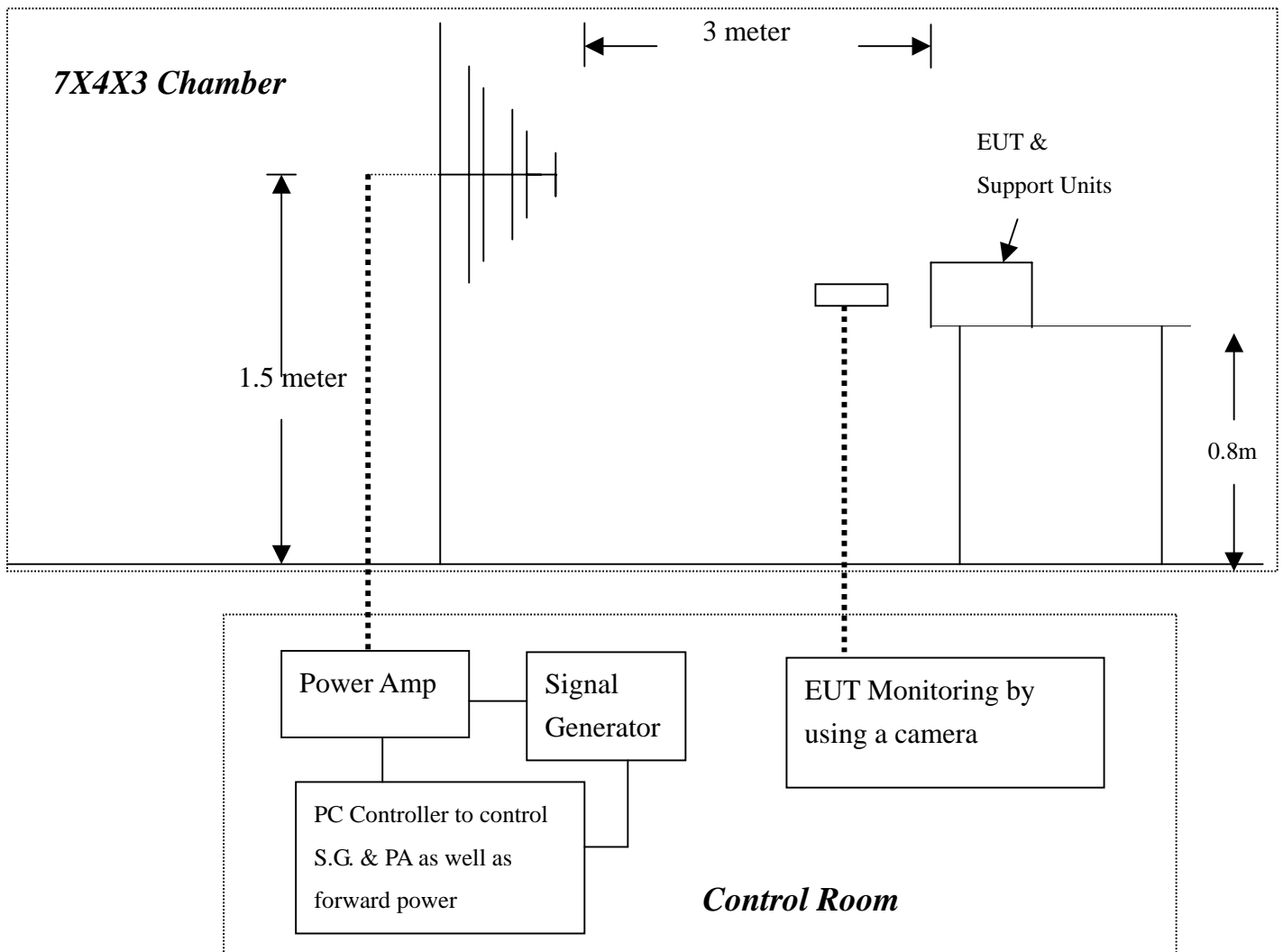



**Test Procedure:**

1. The EUT was located at the edge of supporting table keep 3 meter away from transmitting antenna, it just the calibrated square area of field uniformity. The support units were located outside of the uniformity area, but the cable(s) connected with EUT were exposed to the calibrated field as per IEC 61000-4-3.
2. Set up with the auxiliary equipments, then run the EMCTEST.EXE program in windows XP mode. Make sure the EUT is full load during the test.
3. Setting the testing parameters of RS test software per IEC 61000-4-3.
4. Performing the pre-test at each side of with double specified level (3V/m) at 1% steps.
5. From the result of pre-test in step 5, choose the worst side of EUT for final test from 80 MHz to 1000 MHz at 1% steps.
6. Recording the test result in following table.
7. It is not necessary to perform test as per annex A of EN 55024 if the EUT doesn't belong to TTE product.

**IEC 61000-4-3 test conditions:**

Test level : 3V/m  
 Steps : 1 % of fundamental  
 Dwell Time : 1 sec

Range (MHz)	Field	Modulation	Polarity	Position (°)	Result (Pass/Fail)
80-1000	3V/m	Yes	H	Front	Pass
80-1000	3V/m	Yes	V	Front	Pass
80-1000	3V/m	Yes	H	Right	Pass
80-1000	3V/m	Yes	V	Right	Pass
80-1000	3V/m	Yes	H	Back	Pass
80-1000	3V/m	Yes	V	Back	Pass
80-1000	3V/m	Yes	H	Left	Pass
80-1000	3V/m	Yes	V	Left	Pass

**Performance & Result:**

- Criterion A:** The apparatus continues to operate as intended. No degradation of performance or loss of function is allowed below a performance level specified by the manufacturer, when the apparatus is used as intended. In some cases the performance level may be replaced by a permissible loss of performance.
- Criterion B:** The apparatus continues to operate as intended after the test. No degradation of performance or loss of function is allowed below a performance level specified by the manufacturer, when the apparatus is used as intended. In some cases the performance level may be replaced by a permissible loss of performance. During the test, degradation of performance is however allowed.
- Criterion C:** Temporary loss of function is allowed, provided the functions self-recoverable or can be restored by the operation of controls.

<input checked="" type="checkbox"/> <b>PASS</b>	<input type="checkbox"/> <b>FAIL</b>
---	--------------------------------------

## SECTION 5 IEC 61000-4-4 (FAST TRANSIENTS/BURST)

### FAST TRANSIENTS/BURST IMMUNITY TEST

<b>Port</b>	: On Power Supply Lines
<b>Basic Standard</b>	: IEC 61000-4-4: 2001
<b>Requirements</b>	: +/-1KV for Power Supply Lines
<b>Performance Criterion</b>	: B ( Standard require )
<b>Temperature</b>	: 25°C
<b>Humidity</b>	: 55%

#### Block Diagram of Test Setup:

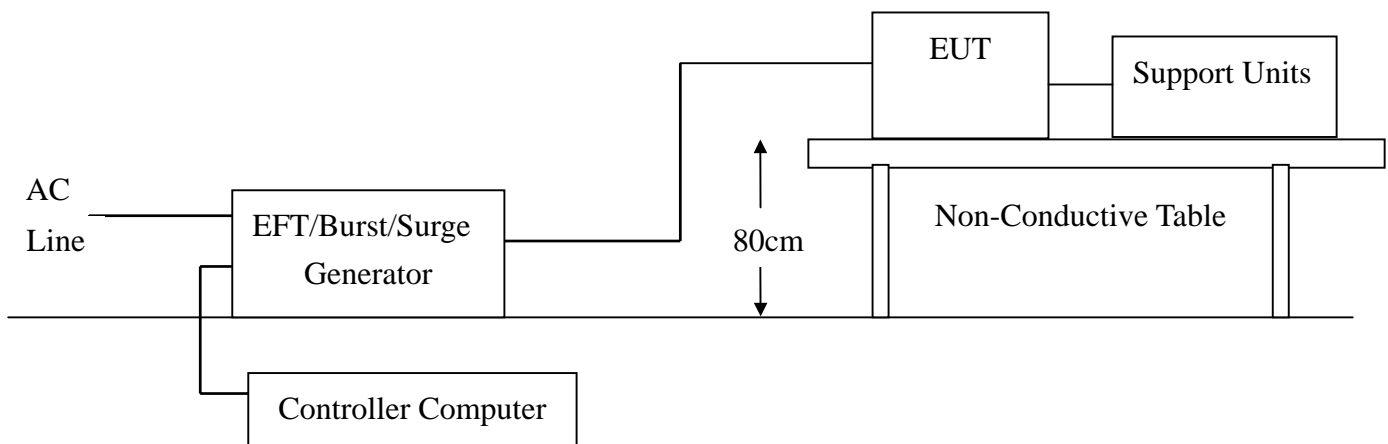



**Test Procedure:**

1. The EUT and support units were located on a wooden table 0.8 m away from ground reference plane.
2. A 1.0 meter long power cord was attached to EUT during the test.
3. The length of communication cable between communication port and clamp was keeping within 1 meter.
4. Set up with the auxiliary equipments, then run the EMCTEST.EXE program in windows XP mode. Make sure the EUT is full load during the test.
5. Related peripherals work during the test.
6. Recording the test result as shown in following table.

**Test conditions:**

Impulse Frequency: 5kHz  
 Tr/Th: 5/50ns  
 Burst Duration: 15ms  
 Burst Period: 300ms

Inject Line	Voltage kV	Inject Method	Result (Pass/Fail)
L	+/- 1	Direct	Pass
N	+/- 1	Direct	Pass
PE	+/- 1	Direct	Pass
L+N	+/- 1	Direct	Pass
L+PE	+/- 1	Direct	Pass
N+PE	+/- 1	Direct	Pass
L+N+PE	+/- 1	Direct	Pass

**Performance & Result:**

- Criterion A:** The apparatus continues to operate as intended. No degradation of performance or loss of function is allowed below a performance level specified by the manufacturer, when the apparatus is used as intended. In some cases the performance level may be replaced by a permissible loss of performance.
- Criterion B:** The apparatus continues to operate as intended after the test. No degradation of performance or loss of function is allowed below a performance level specified by the manufacturer, when the apparatus is used as intended. In some cases the performance level may be replaced by a permissible loss of performance. During the test, degradation of performance is however allowed.
- Criterion C:** Temporary loss of function is allowed, provided the functions self recoverable or can be restored by the operation of controls.

<input checked="" type="checkbox"/> <b>PASS</b>	<input type="checkbox"/> <b>FAIL</b>
---	--------------------------------------

## SECTION 6 IEC 61000-4-5 ( SURGE IMMUNITY )

### SURGE IMMUNITY TEST

**Port** : On Power Supply Lines  
**Basic Standard** : IEC 61000-4-5: 2001  
**Requirements** : +/- 1kV (Line to Line)  
: +/- 2kV (Line to Ground)  
**Performance Criterion:** B ( Standard require )  
**Temperature** : 25°C  
**Humidity** : 56%

### Block Diagram of Test Setup:

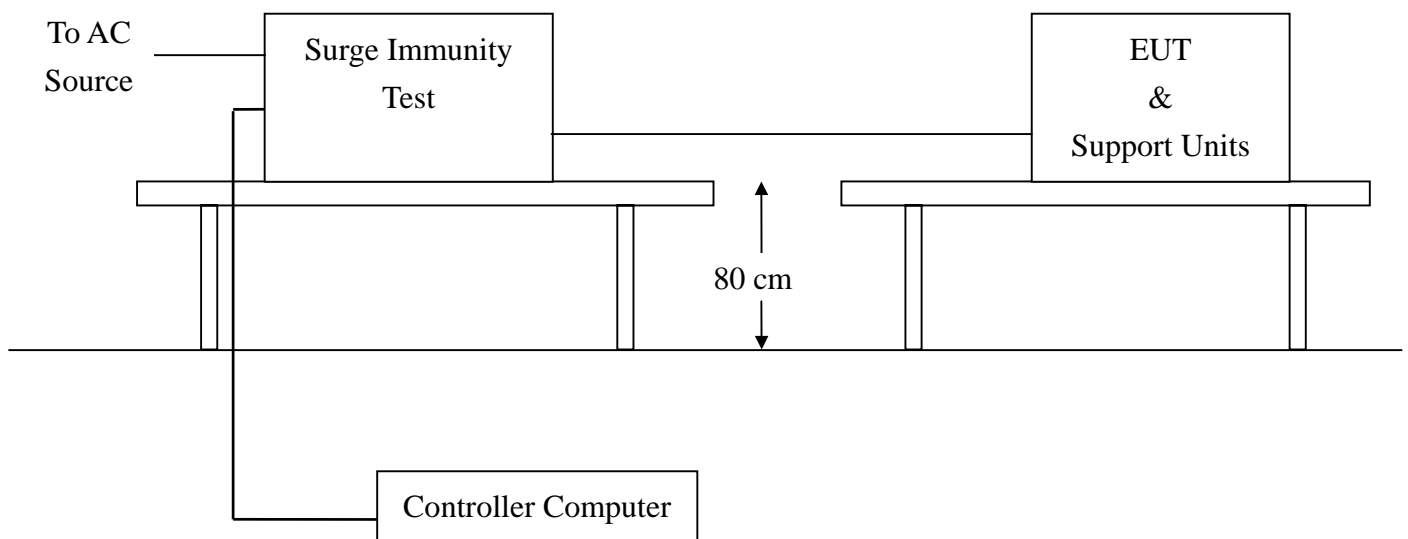



**Test Procedure:**

1. The EUT and support units were located on a wooden table 0.8 m away from ground floor.
2. Set up with the auxiliary equipments, then run the EMCTEST.EXE program in windows XP mode. Make sure the EUT is full load during the test.
3. Recording the test result as shown in following table.

**Test conditions:**

Voltage Waveform : 1.2/50 us  
 Current Waveform : 8/20 us  
 Polarity : Positive/Negative  
 Phase angle : 0°, 90°, 270°  
 Number of Test : 5

Coupling Line	Voltage (kV)	Polarity	Coupling Method	Result (Pass/Fail)
L1-L2	1	Positive	Capacitive	Pass
L1-PE	2	Positive	Capacitive	Pass
L2-PE	2	Positive	Capacitive	Pass
L1-L2	1	Negative	Capacitive	Pass
L1-PE	2	Negative	Capacitive	Pass
L2-PE	2	Negative	Capacitive	Pass

**Performance & Result:**

- Criterion A:** The apparatus continues to operate as intended. No degradation of performance or loss of function is allowed below a performance level specified by the manufacturer, when the apparatus is used as intended. In some cases the performance level may be replaced by a permissible loss of performance.
- Criterion B:** The apparatus continues to operate as intended after the test. No degradation of performance or loss of function is allowed below a performance level specified by the manufacturer, when the apparatus is used as intended. In some cases the performance level may be replaced by a permissible loss of performance. During the test, degradation of performance is however allowed.
- Criterion C:** Temporary loss of function is allowed, provided the functions self recoverable or can be restored by the operation of controls.

<input checked="" type="checkbox"/> <b>PASS</b>	<input type="checkbox"/> <b>FAIL</b>
---	--------------------------------------

## SECTION 7 IEC 61000-4-6(CONDUCTED DISTURBANCE/INDUCED BY RADIO-FREQUENCY FIELD)

**Port** : On Power Supply Lines  
**Basic Standard** : IEC 61000-4-6: 2001  
**Requirements** : 3V with 80% AM. 1kHz Modulation  
**Injection Method** : CDN  
**Performance Criterion** : A (Standard require)  
**Temperature** : 25°C  
**Humidity** : 57%

### Block Diagram of Test Setup:

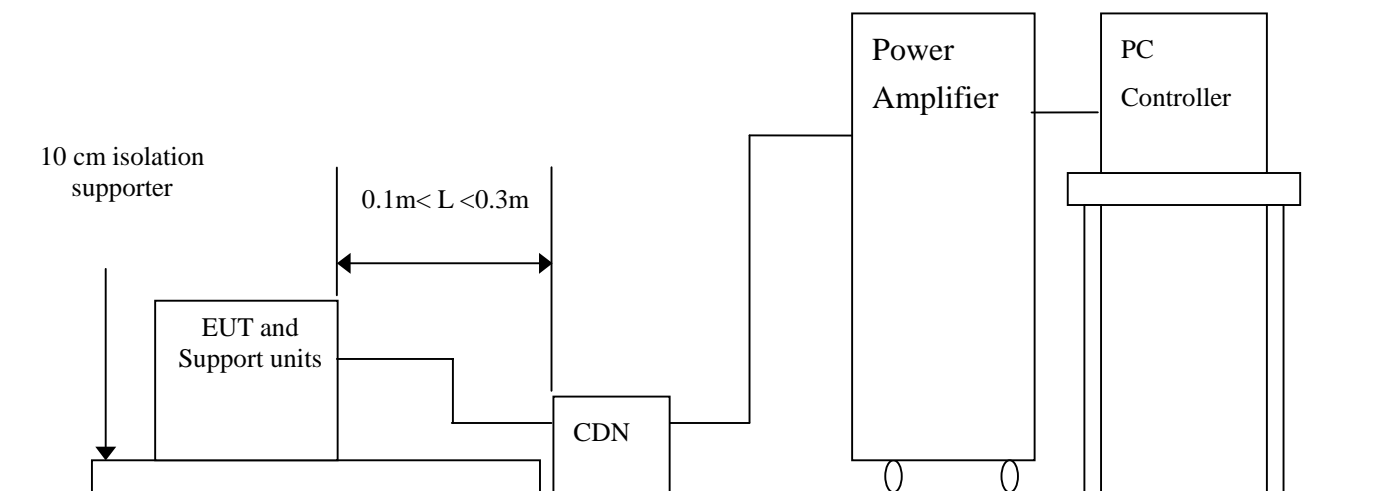



**Test Procedure:**

1. The EUT and support units were located at a ground reference plane with the interposition of a 0.1 m thickness insulating support and the CDN was located on GRP directly.
2. Set up with the auxiliary equipments, then run the EMCTEST.EXE program in windows XP mode. Make sure the EUT is full load during the test.
3. Related peripherals work during the test.
4. Setting the testing parameters of CS test software per IEC 61000-4-6.
5. Recording the test result in following table.

**Test conditions:**

Frequency Range : 0.15MHz-80MHz  
 Frequency Step : 1% of fundamental  
 Dwell Time : 1 sec

Range (MHz)	Field	Modulation	Result (Pass/Fail)
0.15-80	3V	Yes	Pass

**Performance & Result:**

- Criterion A:** The apparatus continues to operate as intended. No degradation of performance or loss of function is allowed below a performance level specified by the manufacturer, when the apparatus is used as intended. In some cases the performance level may be replaced by a permissible loss of performance.
- Criterion B:** The apparatus continues to operate as intended after the test. No degradation of performance or loss of function is allowed below a performance level specified by the manufacturer, when the apparatus is used as intended. In some cases the performance level may be replaced by a permissible loss of performance. During the test, degradation of performance is however allowed.
- Criterion C:** Temporary loss of function is allowed, provided the functions self-recoverable or can be restored by the operation of controls.

<input checked="" type="checkbox"/> <b>PASS</b>	<input type="checkbox"/> <b>FAIL</b>
---	--------------------------------------

## SECTION 8 IEC 61000-4-11 (VOLTAGE DIPS, SHORT INTERRUPTIONS AND VOLTAGE VARIATIONS )

### VOLTAGE DIPS / SHORT INTERRUPTIONS

**Port** : On Power Supply Lines  
**Basic Standard** : IEC 61000-4-11: 2001  
**Requirement** : PHASE ANGLE 0, 45, 90, 135, 180, 225, 270, 315 degrees

Voltage Dips	Test Level % U <sub>T</sub>	Reduction (%)	Duration ( periods )	Performance Criterion
	<5	>95	0.5	B
70	30	25	C	

Voltage Interruptions	Test Level % U <sub>T</sub>	Reduction (%)	Duration ( periods )	Performance Criterion
	<5	>95	250	C

**Test Interval** : Min. 10 sec.  
**Temperature** : 25°C  
**Humidity** : 56%

### Block Diagram of Test Setup:

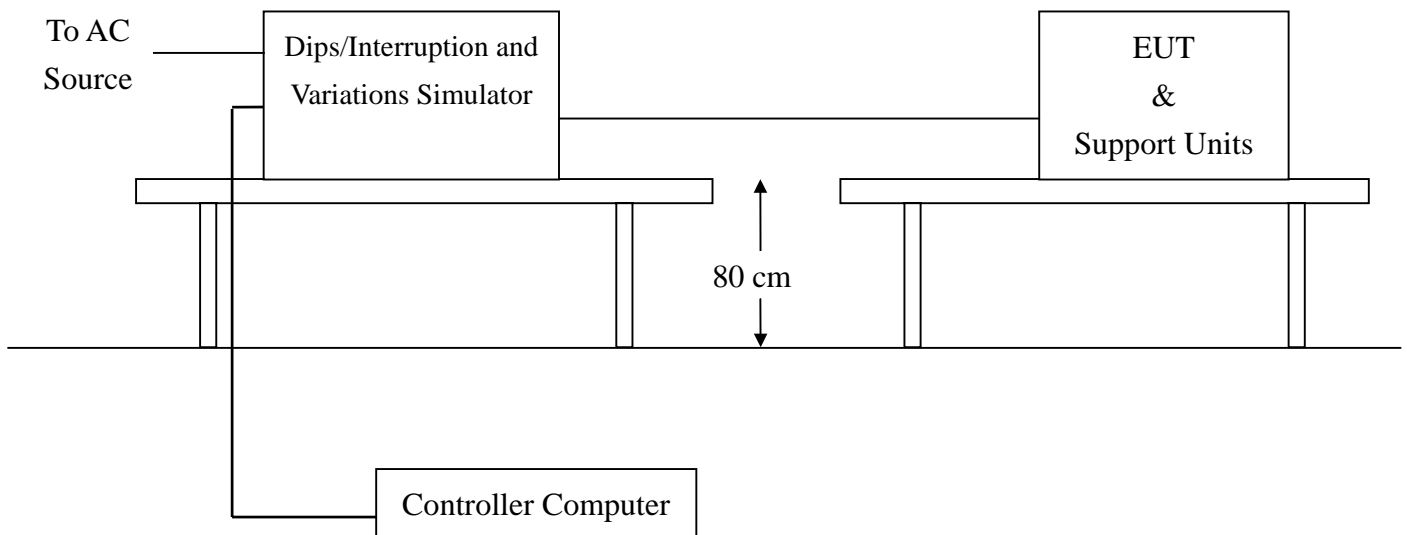



**Test Procedure:**

1. The EUT and support units were located on a wooden table, 0.8 m away from ground floor.
2. Set up with the auxiliary equipments, then run the EMCTEST.EXE program in windows XP mode. Make sure the EUT is full load during the test.
3. Setting the parameter of tests and then Perform the test software of test simulator.
4. Conditions changes to occur at 0 degree crossover point of the voltage waveform.
5. Recording the test result in test record form.

**Test conditions:**

The duration with a sequence of three dips/interruptions with interval of 10 s minimum  
( Between each test event )

**Voltage Dips:**

Test Level % U <sub>T</sub>	Reduction (%)	Duration ( periods)	Observation	Meet Performance Criterion
0	100	0.5	Normal	A
70	30	25	EUT interrupts shortly, but can recover by itself.	B

**Voltage Interruptions:**

Test Level % U <sub>T</sub>	Reduction (%)	Duration ( periods)	Observation	Meet Performance Criterion
0	100	250	EUT interrupts shortly, but can recover by itself.	B

**Performance & Result:**

**Criterion A:** The apparatus continues to operate as intended. No degradation of performance or loss of function is allowed below a performance level specified by the manufacturer, when the apparatus is used as intended. In some cases the performance level may be replaced by a permissible loss of performance.

**Criterion B:** The apparatus continues to operate as intended after the test. No degradation of performance or loss of function is allowed below a performance level specified by the manufacturer, when the apparatus is used as intended. In some cases the performance level may be replaced by a permissible loss of performance. During the test, degradation of performance is however allowed.

**Criterion C:** Temporary loss of function is allowed, provided the functions self recoverable or can be restored by the operation of controls.

<input checked="" type="checkbox"/> <b>PASS</b>	<input type="checkbox"/> <b>FAIL</b>
---	--------------------------------------



## **APPENDIX 1**

### **PHOTOGRAPHS OF TEST SETUP**

## LINE CONDUCTED EMISSION TEST (EN 55022)



## RADIATED EMISSION TEST (EN 55022)





## POWER HARMONIC & VOLTAGE FLUCTUATION / FLICKER TEST (EN 61000-3-2, EN 61000-3-3)



## ELECTROSTATIC DISCHARGE TEST (IEC 61000-4-2)

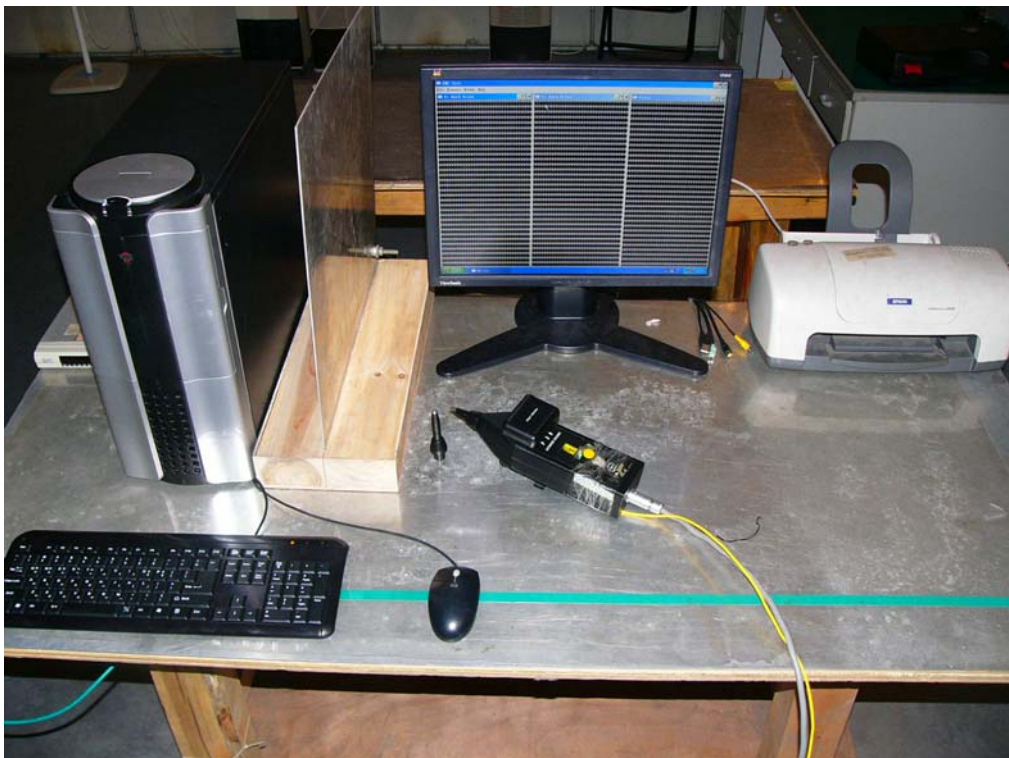

## **RADIATED ELECTROMAGNETIC FIELD (IEC 61000-4-3)**





**FAST TRANSIENTS/BURST TEST (IEC 61000-4-4)  
SURGE IMMUNITY TEST (IEC 61000-4-5)  
VOLTAGE DIPS / INTERRUPTION TEST (IEC 61000-4-11)**





**CONDUCTED DISTURBANCE, INDUCED BY RADIO-FREQUENCY  
FIELDS TEST (IEC 61000-4-6)**

