



## FCC CLASS B COMPLIANCE REPORT

(DoC)

for

Electromagnetic Emissions

of

**Motherboard**

**Trade Name** : JETWAY

**Model Number** : J7F4B1G5D (Please see P5 for all the trade names and model numbers)

**Serial Number** : N/A

**Report Number** : SZ061031B05-EF

**Date** : December 29, 2006

Prepared for :

**JET WAY INFORMATION CO., LTD**  
**4F, NO.168, LITEHST, CHUNG AO CITY 235, TAIPEI, TAIWAN R.O.C**

Prepared by :

**COMPLIANCE CERTIFICATION SERVICES (SHENZHEN) INC.**  
**NO. 5, JINAO INDUSTRIAL PARK, NO. 35 JUKENG ROAD,**  
**DASHUIKENG VILLAGE, GUANLAN TOWN, BAOAN**  
**DISTRICT, SHENZHEN, CHINA**



LAB CODE:200577-0

**TEL: 86-755-28055000**

**FAX: 86-755-28055221**

*Note: This report shall not be reproduced except in full, without the written approval of Compliance Certification Service Inc. . This document may be altered or revised by Compliance Certification Service Inc. personnel only, and shall be noted in the revision section of the document.*



## TABLE OF CONTENTS

| DESCRIPTION   | PAGE |
|---|------|
| TEST RESULT CERTIFICATION                                     | 3    |
| SYSTEM DESCRIPTION  | 4    |
| PRODUCT INFORMATION   | 5    |
| SUPPORT EQUIPMENT   | 6    |
| <b>SECTION 1 FCC (LINE CONDUCTED &amp; RADIATED EMISSION)</b> | 7    |
| MEASUREMENT PROCEDURE & LIMIT (LINE CONDUCTED EMISSION TEST)  | 7    |
| MEASUREMENT PROCEDURE & LIMIT (RADIATED EMISSION TEST)        | 10   |
| SUMMARY DATA  | 13   |
| TEST FACILITY   | 15   |
| TEST EQUIPMENT LIST   | 16   |
| BLOCK DIAGRAM OF TEST SETUP                                   | 17   |
| APPENDIX 1 PHOTOGRAPHS OF TEST SETUP                          | 18   |



### TEST RESULT CERTIFICATION

**Equipment Under Test:** Motherboard

**Trade Name:** JETWAY

**Model Number:** J7F4B1G5D (Please see P5 for all the trade names and model numbers)

**Serial Number:** N/A

**Applicant:** JET WAY INFORMATION CO., LTD  
4F, NO.168, LITEHST, CHUNG AO CITY 235, TAIPEI, TAIWAN  
R.O.C

**Manufacturer 1:** TOP WAY TCHNOLOGY CO., LTD  
SHANG JIN INDUSTRIAL ZONE JIE KOU VILLAGE CHANG AN  
TOWN DONG GUAN CITY GUANG DONG PROVINCE P.R.C

**Manufacturer 2:** EVER ORIENT TECHNOLOGY CO., LTD  
LIAN HE INDUSTRIAL PARK, NAN YUE, LONG GONG,  
SHENZHEN, GUANG DONG, CHINA.

**Manufacturer 3:** RIGHT TRACK ELECTRONIC TECHNOLOGY CO., LTD  
NO.2 WEST WORDSHOP, NO.1 DISTRICT NANCHANG  
INDUSTRIAL ZONE, GUSHU VILLIAGE, XIXIANG TOWN,  
BAOAN, SHENZHEN, P.R.CHINA.

**Type of Test:** FCC Part 15 Subpart B Class B (DoC)

**Measurement Procedure:** ANSI C63.4: 2003

**Report Number:** SZ061031B05-EF

**Date of test:** October 31~December 28, 2006

**Deviation:** None

**Condition of Test Sample:** Normal

The above equipment was tested by Compliance Certification Services (Shenzhen) Inc. for compliance with the requirements set forth in the FCC Rules and Regulations Part 15, Subpart B and the measurement procedure according to ANSI C63.4. This said equipment in the configuration described in this report shows the maximum emission levels emanating from equipment are within the compliance requirements.

The test results of this report relate only to the tested sample identified in this report.

**Approved by:**

**Tested By:** Jason He

Clinton Kao / Manager  
COMPLIANCE CERTIFICATION  
SERVICES (SHENZHEN) INC.

**Reviewed By:**

Vincent Yao / Assistant manager  
COMPLIANCE CERTIFICATION  
SERVICES (SHENZHEN) INC.



## **SYSTEM DESCRIPTION**

### **EUT Test Program:**

1. Set up with the auxiliary equipments, then run the EMCTEST.EXE program in windows XP mode.
2. Keep running the program throughout the test.



### PRODUCT INFORMATION

**Housing Type:** Metal

**EUT Power Rating:** DC5V or DC12V supplied by PC

**Power During Test:** DC5V or DC12V supplied by PC

**Data Cable:** N/A

**I/O Port of EUT:**

| I/O Port Type | Q'TY | Tested with |
|---------------|------|-------------|
| 1) USB Port   | 4    | 4           |
| 2) PS/2 Port  | 2    | 2           |
| 3) RJ45 Port  | 2    | 2           |
| 4) MIC Port   | 1    | 1           |
| 5) Audio Port | 2    | 2           |
| 6) VGA Port   | 1    | 1           |
| 7) DB9 Port   | 1    | 1           |

**Difference between model numbers as below:**

|    | Model Number  | Trade Name |
|----|---|------------|
| 1. | J7F4B1G5D   | JETWAY     |
| 2. | J7F4XYYYY<br>(“X” can be “B” or “K”; “YYYY” can be “0” to “9”, “A” to “Z” or blank) |            |

**SUPPORT EQUIPMENT**

| No. | Equipment     | Model #       | Serial #                     | Trade Name   | Data Cable         | Power Cord         | FCC ID        |
|-----|---------------|---------------|------------------------------|--------------|--------------------|--------------------|---------------|
| 1)  | LCD MONITOR   | VP201B        | A21050102549                 | VIEWSONIC    | Shielded<br>1.8 m  | Unshielded<br>1.8m | N/A           |
| 2)  | MODEM         | SUPERFAX6.0   | 9013593                      | ACEEX        | Shielded<br>1.5m   | Unshielded<br>1.8m | IFXDM14<br>14 |
| 3)  | PRINTER       | C8942A        | TH19T1G0W4                   | HP           | Shielded<br>1.5m   | Unshielded<br>1.8m | N/A           |
| 4)  | PS/2 KEYBOARD | SK-8115       | CN-0J4633-7161<br>6-51A-0KJY | DELL         | Shielded<br>1.6m   | N/A                | N/A           |
| 5)  | PS/2 MOUSE    | M-S69         | 323614-001                   | HP           | Shielded<br>1.8 m  | N/A                | N/A           |
| 6)  | RJ45 CABLE 1  | N/A           | N/A                          | N/A          | Unshielded<br>1.2m | N/A                | N/A           |
| 7)  | USB CABLE 1   | N/A           | N/A                          | N/A          | Unshielded<br>1.5m | N/A                | N/A           |
| 8)  | USB CABLE 2   | N/A           | N/A                          | N/A          | Unshielded<br>1.5m | N/A                | N/A           |
| 9)  | USB CABLE 3   | N/A           | N/A                          | N/A          | Unshielded<br>1.5m | N/A                | N/A           |
| 10) | USB CABLE 4   | N/A           | N/A                          | N/A          | Unshielded<br>1.5m | N/A                | N/A           |
| 11) | AUDIO CABLE 1 | N/A           | N/A                          | N/A          | Unshielded<br>1.2m | N/A                | N/A           |
| 12) | AUDIO CABLE 2 | N/A           | N/A                          | N/A          | Unshielded<br>1.2m | N/A                | N/A           |
| 13) | MIC CABLE     | N/A           | N/A                          | N/A          | Unshielded<br>1.2m | N/A                | N/A           |
| 14) | HD            | M6FYA         | 24094LFJHMER                 | MAXTOR       | N/A                | N/A                | N/A           |
| 15) | PC POWER      | ST-ATX340     | B6058518                     | SHIJIZHIXING | N/A                | N/A                | N/A           |
| 16) | PC BOX        | N/A           | 51200136                     | SHIJIZHIXING | N/A                | N/A                | N/A           |
| 17) | MEMORY EXPERT | DDR-0035      | R670070T                     | V-DATA       | N/A                | N/A                | N/A           |
| 18) | CPU           | C7-D 1500/400 | D6D0T002SB0                  | TAIWAN       | N/A                | N/A                | N/A           |
| 19) | CPU FAN       | DFB401012M    | N/A                          | YOUNG LIN    | N/A                | N/A                | N/A           |

**\*\*Note:** All the above equipment/cables were placed in worse case positions to maximize emission signals during emission test.

**Grounding:** Grounding was in accordance with the manufacturer's requirements and conditions for the intended use.



# SECTION 1 FCC (LINE CONDUCTED & RADIATED EMISSION)

## MEASUREMENT PROCEDURE

### (PRELIMINARY LINE CONDUCTED EMISSION TEST)

- 1) The equipment was set up as per the test configuration to simulate typical actual usage per the user’s manual. When the EUT is a tabletop system, a wooden table with a height of 0.8 meters is used and is placed on the ground plane as per ANSI C63.4 (see Test Facility for the dimensions of the ground plane used). When the EUT is a floor-standing equipment, it is placed on the ground plane which has a 3-12 mm non-conductive covering to insulate the EUT from the ground plane.
- 2) Support equipment, if needed, was placed as per ANSI C63.4.
- 3) All I/O cables were positioned to simulate typical actual usage as per ANSI C63.4.
- 4) The EUT received DC power from PC power supply, and PC received AC120V/60Hz power through a Line Impedance Stabilization Network (LISN) which supplied power source and was grounded to the ground plane.
- 5) All support equipments received AC120V/60Hz power from a second LISN, if any.
- 6) The EUT test program was started. Emissions were measured on each current carrying line of the EUT using a spectrum Analyzer / Receiver connected to the LISN powering the EUT. The LISN has two monitoring points: Line 1 (Hot Side) and Line 2 (Neutral Side). Two scans were taken: one with Line 1 connected to Analyzer / Receiver and Line 2 connected to a 50 ohm load; the second scan had Line 1 connected to a 50 ohm load and Line 2 connected to the Analyzer / Receiver.
- 7) Analyzer / Receiver scanned from 150kHz to 30MHz for emissions in each of the test modes.
- 8) During the above scans, the emissions were maximized by cable manipulation.
- 9) The following test mode(s) were scanned during the preliminary test:

| <b>Preliminary Conducted Emission Test</b> |            |                   |                                     |
|--|------------|-------------------|-------------------------------------|
| Frequency Range Investigated               |            | 150KHz TO 30 MHz  |                                     |
| Mode of operation                          | Date       | Data Report No.   | Worst Mode                          |
| Full Cable                                 | 2006-12-27 | J7F4B1G5D_0(L, N) | <input checked="" type="checkbox"/> |

Then, the EUT configuration and cable configuration of the above highest emission level were recorded for reference of final testing.



### MEASUREMENT PROCEDURE (FINAL LINE CONDUCTED EMISSION TEST)

- 1) EUT and support equipment was set up on the test bench as per step 9 of the preliminary test.
- 2) A scan was taken on both power lines, Line 1 and Line 2, recording at least the six highest emissions. Emission frequency and amplitude were recorded into a computer in which correction factors were used to calculate the emission level and compare reading to the applicable limit. If EUT emission level was less -2dB to the A.V. limit in Peak mode, then the emission signal was re-checked using Q.P and Average detector.
- 3) The test data of the worst case condition(s) was reported on the Summary Data page.

**Data Sample:**

| Freq.<br>MHz | Peak<br>Raw<br>dBuV | Q.P.<br>Raw<br>dBuV | Average<br>Raw<br>dBuV | Q.P.<br>Limit<br>dBuV | Average<br>Limit<br>dBuV | Q.P.<br>Margin<br>dB | Average<br>Margin<br>dB | Note |
|--------------|---------------------|---------------------|------------------------|-----------------------|--------------------------|----------------------|-------------------------|------|
| x.xxx        | 43.90               | ---                 | ---                    | 56.00                 | 46.00                    | ---                  | -2.10                   | L 1  |

Freq. = Emission frequency in MHz  
Raw dBuV = Uncorrected Analyzer/Receiver reading  
Limit dBuV = Limit stated in standard  
Margin dB = Reading in reference to limit  
Note = Current carrying line of reading  
“---“ = The emission level complied with the Average limits, with at least 2 dB margin, so no further recheck.



### LINE CONDUCTED EMISSION LIMIT

| Frequency     | Maximum RF Line Voltage |               |
|---------------|-------------------------|---------------|
|               | Q.P.( dBuV)             | AVERAGE(dBuV) |
| 150kHz-500kHz | 66-56                   | 56-46         |
| 500kHz-5MHz   | 56                      | 46            |
| 5MHz-30MHz    | 60                      | 50            |

**\*\*Note:** The lower limit shall apply at the transition frequency.



**MEASUREMENT PROCEDURE  
(PRELIMINARY RADIATED EMISSION TEST)**

- 1) The equipment was set up as per the test configuration to simulate typical actual usage per the user’s manual. When the EUT is a tabletop system, a wooden turntable with a height of 0.8 meters is used which is placed on the ground plane as per ANSI C63.4 (see Test Facility for the dimensions of the ground plane used). When the EUT is a floor-standing equipment, it is placed on the ground plane which has a 3-12 mm non-conductive covering to insulate the EUT from the ground plane.
- 2) Support equipment, if needed, was placed as per ANSI C63.4.
- 3) All I/O cables were positioned to simulate typical actual usage as per ANSI C63.4.
- 4) The EUT received DC power from PC power supply, and PC received AC120V/60Hz power through the outlet socket under the turntable. All support equipments received AC 120V/60Hz power from socket under the turntable, if any.
- 5) The antenna was placed at 10 meter away from the EUT as stated in ANSI C63.4. The antenna connected to the Analyzer via a cable and at times a pre-amplifier would be used.
- 6) The Analyzer / Receiver quickly scanned from 30MHz to 1000MHz. The EUT test program was started. Emissions were scanned and measured rotating the EUT to 360 degrees and positioning the antenna 1 to 4 meters above the ground plane, in both the vertical and the horizontal polarization, to maximize the emission reading level.
- 7) The following test mode(s) were scanned during the preliminary test:

| <b>Preliminary Radiated Emission Test</b> |            |                    |                                     |
|---|------------|--------------------|-------------------------------------|
| Frequency Range Investigated              |            | 30 MHz TO 1000 MHz |                                     |
| Mode of operation                         | Date       | Data Report No.    | Worst Mode                          |
| Full Cable                                | 2006-12-25 | J7F4B1G5D_0(H, V)  | <input checked="" type="checkbox"/> |

Then, the EUT and cable configuration, antenna position, polarization and turntable position of the above highest emission level were recorded for final testing.



### MEASUREMENT PROCEDURE (FINAL RADIATED EMISSION TEST)

- 1) EUT and support equipment were set up on the turntable as per step 7 of the preliminary test.
- 2) The Analyzer / Receiver scanned from 30MHz to 1000MHz. Emissions were scanned and measured rotating the EUT to 360 degrees, varying cable placement and positioning the antenna 1 to 4 meters above the ground plane, in both the vertical and the horizontal polarization, to maximize the emission reading level.
- 3) Recorded at least the six highest emissions. Emission frequency, amplitude, antenna position, polarization and turntable position were recorded into a computer in which correction factors were used to calculate the emission level and compare reading to the applicable limit and Q.P/Peak. reading is presented.
- 4) The test data of the worst case condition(s) was reported on the Summary Data page.

**Data Sample:**

| Freq.<br>(MHz) | Raw<br>Data<br>(dBuV/m) | Corr.<br>Factor<br>(dB) | Emiss.<br>Level<br>( dBuV/m ) | Limits | Margin<br>(dB) | Reading<br>Type<br>P/Q |
|----------------|-------------------------|-------------------------|-------------------------------|--------|----------------|------------------------|
| xx.xxx         | 14.02                   | 12.25                   | 26.27                         | 30.00  | -3.73          | P                      |

- Freq. = Emission frequency in MHz
- Raw Data (dBuV/m) = Uncorrected Analyzer / Receiver reading
- Corr. Factor (dB) = Correction factors of antenna factor and cable loss
- Emiss. Level = Raw reading converted to dBuV/m and CF added
- Limit dBuV/m = Limit stated in standard
- Margin dB = Reading in reference to limit
- P =Peak Reading
- Q =Quasi-peak



## RADIATED EMISSION LIMIT

| Frequency<br>(MHz) | Distance<br>(m) | Maximum Field Strength Limit<br>(dBuV/m/ Q.P.) |
|--------------------|-----------------|--|
| 30-230             | 10              | 30.00  |
| 230-1000           | 10              | 37.00  |

**\*\*Note:** The lower limit shall apply at the transition frequency.



## SUMMARY DATA (LINE CONDUCTED TEST)

**Model Number:** J7F4B1G5D**Location:** Site G**Tested by:** Jason**Test Mode:** Full Cable**Test Results:** Passed**Temperature:** 25°C**Humidity:** 55%RH

(The chart below shows the highest readings taken from the final data)

| FREQ<br>MHz | PEAK<br>RAW<br>dBuV | Q.P.<br>RAW<br>dBuV | AVG<br>RAW<br>dBuV | Q.P.<br>Limit<br>dBuV | AVG<br>Limit<br>dBuV | Q.P.<br>Margin<br>dB | AVG<br>Margin<br>dB | NOTE |
|-------------|---------------------|---------------------|--------------------|-----------------------|----------------------|----------------------|---------------------|------|
| 0.168       | 55.62               | 54.47               | 44.93              | 65.47                 | 55.47                | -11.00               | -10.54              | L1   |
| 0.205       | 49.83               | ---                 | ---                | 64.41                 | 54.41                | ---                  | -4.58               | L1   |
| 0.238       | 46.68               | ---                 | ---                | 63.46                 | 53.46                | ---                  | -6.78               | L1   |
| 0.309       | 44.05               | ---                 | ---                | 61.45                 | 51.45                | ---                  | -7.40               | L1   |
| 0.368       | 43.98               | ---                 | ---                | 59.75                 | 49.75                | ---                  | -5.77               | L1   |
| 0.435       | 51.08               | 48.99               | 35.99              | 57.84                 | 47.84                | -8.85                | -11.85              | L1   |
| 0.168       | 54.02               | 50.84               | 41.31              | 65.47                 | 55.47                | -14.63               | -14.16              | L2   |
| 0.235       | 46.02               | ---                 | ---                | 63.56                 | 53.56                | ---                  | -7.54               | L2   |
| 0.305       | 43.36               | ---                 | ---                | 61.55                 | 51.55                | ---                  | -8.19               | L2   |
| 0.368       | 44.47               | ---                 | ---                | 59.75                 | 49.75                | ---                  | -5.28               | L2   |
| 0.439       | 49.99               | 47.98               | 35.55              | 57.74                 | 47.74                | -9.76                | -12.19              | L2   |
| 4.629       | 31.19               | ---                 | ---                | 56.00                 | 46.00                | ---                  | -14.81              | L2   |

*L1 = Line One (Hot side) / L2 = Line Two (Neutral side)***\*\*NOTE:** “---” denotes the emission level was or more than 2dB below the Average limit, so no re-check anymore.

**SUMMARY DATA****(RADIATED EMISSION TEST)****Model Number:** J7F4B1G5D**Location:** Site G**Tested by:** Jason**Polar:** Vertical / Horizontal**Test Mode:** Full Cable**Test distance:** 10m**Test Results:** Passed**Temperature:** 25°C**Humidity:** 55%RH

(The chart below shows the highest readings taken from the final data)

| Frequency Range Investigated (30 MHz TO 1000 MHz) |                       |                         |                          |                        |                          |             |      |
|---|-----------------------|-------------------------|--------------------------|------------------------|--------------------------|-------------|------|
| Freq.<br>(MHz)                                    | Reading(RA)<br>(dBuV) | Corr.Factor(CF)<br>(dB) | Measured(FS)<br>(dBuV/m) | Limits(QP)<br>(dBuV/m) | Safe Margins<br>(dBuV/m) | Ant.<br>H/V | Mark |
| 132.552   | 33.67                 | -6.97                   | 26.70                    | 30.00                  | -3.30                    | V           | Q.P  |
| 166.648   | 34.31                 | -8.50                   | 25.81                    | 30.00                  | -4.19                    | V           | Peak |
| 297.212   | 32.03                 | -3.53                   | 28.50                    | 37.00                  | -8.50                    | V           | Peak |
| 433.224   | 27.80                 | -1.28                   | 26.52                    | 37.00                  | -10.48                   | V           | Peak |
| 534.064   | 29.57                 | 1.10                    | 30.67                    | 37.00                  | -6.33                    | V           | Peak |
| 601.500   | 29.22                 | -0.27                   | 28.95                    | 37.00                  | -8.05                    | V           | Peak |
| 132.584   | 31.97                 | -4.93                   | 27.04                    | 30.00                  | -2.96                    | H           | Peak |
| 231.124   | 30.17                 | -0.68                   | 29.49                    | 37.00                  | -7.51                    | H           | Peak |
| 503.272   | 29.17                 | -1.14                   | 28.03                    | 37.00                  | -8.97                    | H           | Peak |
| 533.932   | 33.43                 | 1.00                    | 34.43                    | 37.00                  | -2.57                    | H           | Q.P  |
| 562.476   | 26.81                 | 1.89                    | 28.70                    | 37.00                  | -8.30                    | H           | Peak |
| 594.136   | 27.56                 | 1.29                    | 28.85                    | 37.00                  | -8.15                    | H           | Peak |

$C.F.(\text{Correction Factor}) = \text{Antenna Factor} + \text{Cable Loss} - \text{Amplifier Gain} (+ \text{Attenuator } 6\text{dB})$

$\text{Corrected Reading} = \text{Metering Reading} + C.F.$

$\text{Margin} = \text{Corrected Reading} - \text{Limits}$

$P = \text{Peak Reading}$

$H = \text{Horizontal Polarization/Antenna}$

$Q = \text{Quasi-peak}$

$V = \text{Vertical Polarization/Antenna}$

Comments: N/A



## TEST FACILITY

- Location:** No. 5, Jinao industrial park, No. 35 Jukeng Road, Dashuikeng Village, Guanlan Town, Baoan District, Shenzhen, China
- Description:** There is one 3/10m open area test sites and one line conducted labs for final test.  
The Open Area Test Sites and the Line Conducted labs are constructed and calibrated to meet the FCC requirements in documents ANSI C63.4 and CISPR 22/EN 55022 requirements.
- Site Filing:** A site description is on file with the Federal Communications Commission, 7435 Oakland Mills Road, Columbia, MD 21046.
- Site Accreditation:** Accredited by Nemko ( Aut. No.: ELA106), VCCI(Registration No.: R-1996,C-2150), FCC ( Registration No.: 101879 and NVLAP(Lab code:200577-0) for EMC.
- Instrument Tolerance:** All measuring equipment is in accord with ANSI C63.4 and CISPR 22 requirements that meet industry regulatory agency and accreditation agency requirement.
- Ground Plane:** Two conductive reference ground planes were used during the Line Conducted Emission, one in vertical and the other in horizontal. The dimensions of these ground planes are as below. The vertical ground plane was placed distancing 40 cm to the rear of the wooden test table on where the EUT and the support equipment were placed during test. The horizontal ground plane projected 50 cm beyond the footprint of the EUT system and distanced 80 cm to the wooden test table. For Radiated Emission Test, one horizontal conductive ground plane extended at least 1m beyond the periphery of the EUT and the largest measuring antenna, and covered the entire area between the EUT and the antenna. It has no holes or gaps having longitudinal dimensions larger than one-tenth of a wavelength at the highest frequency of measurement above 1GHz.



## TEST EQUIPMENT LIST

**Instrumentation:** The following list contains equipment used at Compliance Certification Services (Shenzhen) Inc. for testing. The equipment conforms to the CISPR 16-1 / ANSI C63.2 Specifications for Electromagnetic Interference and Field Strength Instrumentation from 10kHz to 1.0GHz or above.

**Equipment used during the tests:**

**Open Area Test Site:** G

| Open Area Test Site G |                |              |               |            |            |
|-----------------------|----------------|--------------|---------------|------------|------------|
| EQUIPMENT TYPE        | MFR            | MODEL NUMBER | SERIAL NUMBER | LAST CAL.  | CAL. DUE   |
| EMI Test Receiver     | ROHDE&SCHWARZ  | ESCI         | 100145        | 02/09/2006 | 02/08/2007 |
| Pre Amplifier         | H.P.           | 8447D        | 2944A06833    | 09/01/2006 | 09/01/2007 |
| Bi-log Antenna        | SCHAFFNER      | CBL6143      | 5082          | 06/10/2006 | 06/09/2007 |
| Cable                 | TIME MICROWAVE | LMR-400      | N-TYPE04      | 06/10/2006 | 06/09/2007 |
| System-Controller     | CT             | SC100        | N/A           | N/A        | N/A        |
| Turn Table            | EMCO           | 2081-1.21    | N/A           | N/A        | N/A        |
| Antenna Tower         | CT             | N/A          | N/A           | N/A        | N/A        |

*Note: The measure uncertainty is less than  $\pm 2.5078\text{dB}$ , which is evaluated as per the UKAS LAB34 and CISPR/A/291/CDV.*

**Conducted Emission Test Site:** G

| Conducted Emission Test Site G |               |              |               |            |            |
|--------------------------------|---------------|--------------|---------------|------------|------------|
| EQUIPMENT TYPE                 | MFR           | MODEL NUMBER | SERIAL NUMBER | LAST CAL.  | CAL. DUE   |
| EMI Test Receiver              | ROHDE&SCHWARZ | ESCI         | 100088        | 02/09/2006 | 02/08/2007 |
| LISN                           | EMCO          | 3825/2       | 1371          | 02/09/2006 | 02/08/2007 |
| LISN                           | EMCO          | 3825/2       | 8901-1459     | 02/09/2006 | 02/08/2007 |

*Note: The measure uncertainty is less than  $\pm 2.2318\text{dB}$ , which is evaluated as per the UKAS LAB34 and CISPR/A/291/CDV.*

The calibrations of the measuring instruments, including any accessories that may effect such calibration, are checked frequently to assure their accuracy. Adjustments are made and correction factors applied in accordance with instructions contained in the manual for the measuring instrument.



## BLOCK DIAGRAM OF TEST SETUP

### System Diagram of Connections between EUT and Simulators

**EUT :** Motherboard  
**Trade Name:** JETWAY  
**Model Number:** J7F4B1G5D

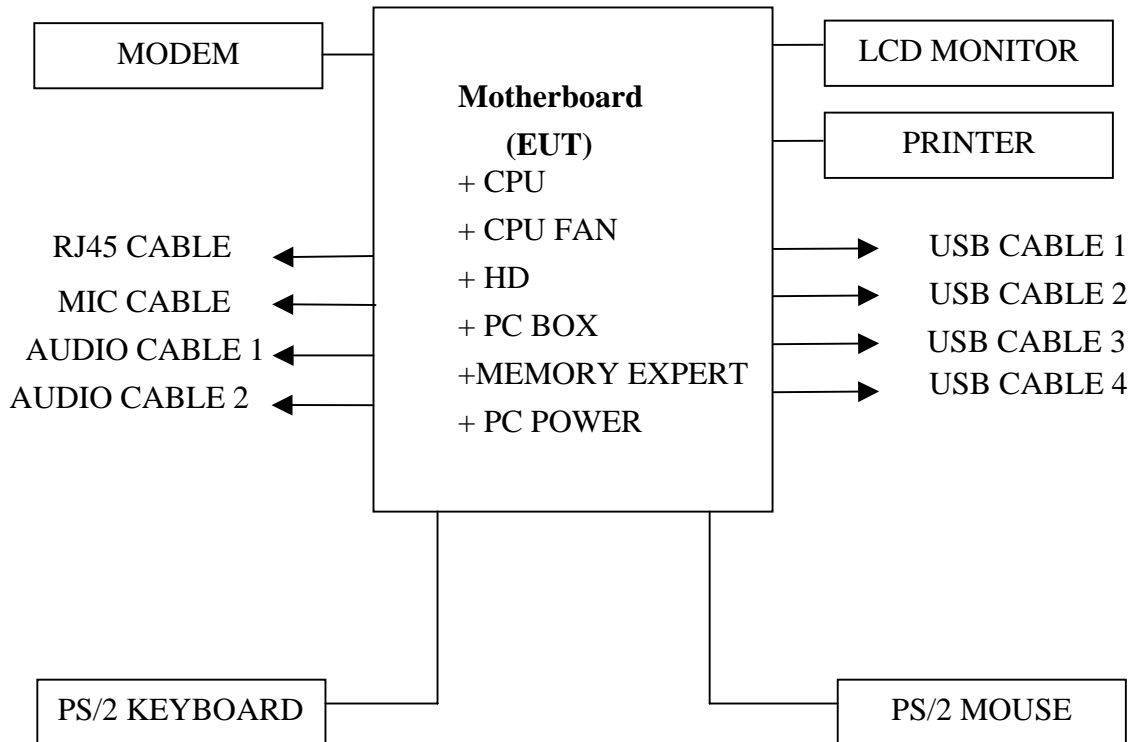



## **APPENDIX 1**

### **PHOTOGRAPHS OF TEST SETUP**



### LINE CONDUCTED EMISSION TEST





## RADIATED EMISSION TEST

